

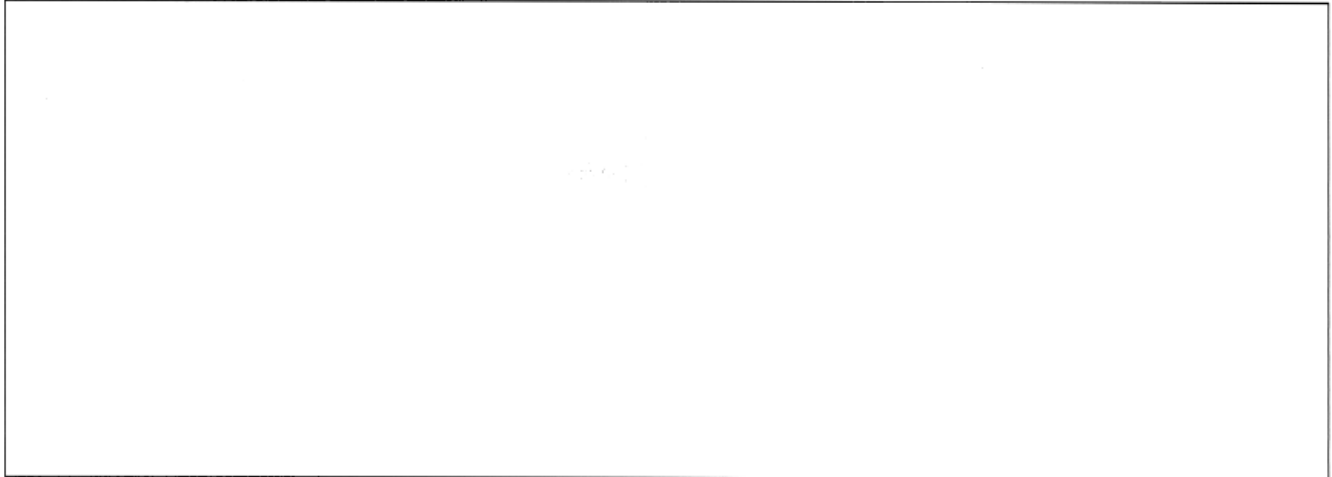

INSTRUCTION MANUAL
FSM
Frequency Scaling Module

Form 168-701-00B

January 1982



GENERAL INFORMATION

1.1 SCOPE OF MANUAL

This manual contains operating and maintenance information for the Frequency Scaling Module (FSM), manufactured by MOORE INDUSTRIES INC., Sepulveda, California. The manual consists of six sections as follows:

Section 1, General Information, introduces the equipment function and describes the equipment physical appearance, the equipment specifications, and options available for the unit. The introduction also provides information on the use and description of the MOORE model numbering system.

Section 2, Calibration, provides all the information necessary to calibrate the unit before installation. This section contains a list of the tools necessary for calibrating the equipment; and illustrates the test setups essential to perform that task. The section also lists the various procedures required for calibration of the units in any configuration.

Section 3, Installation and Operation, supplies all the information needed to install and operate the equipment. The section contains figures that specify the installation requirements for the units, and text that informs the user on recommended wiring practices for the equipment as well as defines the electrical connections for each unit regardless of physical modifications. A brief outline of periodic observations required during the equipment operation is also included here.

Section 4, Theory of Operation, gives the maintenance personnel a detailed explanation of the internal function of the unit. The circuit theory is based on a block diagram that shows the functional elements of the unit. Each element operation is then described, first in relation to the other element, then independently where its major components' use and purpose are described.

Section 5, Maintenance, offers complete disassembly procedures for all unit configurations available. Troubleshooting information is also provided in this section as well as component replacement techniques to aid the technician in the repair of the equipment.

Section 6, Unit Documentation, acquaints the user with the MOORE IND. computerized parts listing and identification system. The section also provides a recommended spare parts list. All schematics and parts assembly drawings referred to by the text are located in the back of Section 6.

1.2 EQUIPMENT DESCRIPTION

The Frequency Scaling Module (FSM) accepts inputs of a certain frequency and scales it to another convenient frequency. Thus it accepts inputs from such devices as turbine meters, positive displacement pumps, gear-teeth pick-offs and converts the pulse rate to a more convenient engineering unit such as gallons or feet. An optional output produces a DC voltage or current proportional to the frequency of the input signal. This option is only available on FSM units in a PM housing.

1.3 PHYSICAL DESCRIPTION

The FSM generally consists of two printed-circuit boards, one mounted to the other. The small board holds the input and selection circuits while the main board (PC1) holds the remaining circuits as well as the selection switches. An additional board (PCA) is used to house the DC to AC power converter. This board is omitted when the FSM is powered by an AC source.

In the PM units, two additional boards are optionally used to make the control switches accessible to the front of the unit. In this case, the switches are removed from the main board. In their place, a board (PC3) plugs into the main board switch connection. PC3 in turn is the PC receptacle for a flex cable connection. The other end of the cable terminates into another board, PC4. This board holds the control switches that are mounted on the front panel.

If the AO option is specified, three more boards are added to the unit in the PM enclosure. Two smaller boards are mounted to another main board (PC5) and this assembly is mounted below the PC1 assembly. This assembly contains its own power supply and, if DC power is selected, its own PCA (DC/AC Inverter) board. The board mounted to the end of PC5 contains the power supply filters to the side of PC5 contains a crystal oscillator and digital one-shot logic circuits, while PC5 holds the input circuits, low-pass filters, and analog output circuits.



Standard (STD) Unit

1.3.1 Conduit Plate Option (CP) Description

This option consists of an extension of the standard bracket lower mounting flange. The additional surface is cut with two mounting holes to accommodate 1/2-inch electrical conduit. This option is illustrated in the next section outline and dimension drawings.

1.3.2 Angle Bracket (AB) Option Description

This option consists of two angle brackets, one on the top and the other on the bottom of the unit. These brackets are used to mount the unit in applications where the standard U-bracket will not apply. The brackets are provided with two #10 screw clearance holes each, for ease of mounting.



Unit with Angle Bracket (AB) Option

1.3.3 NEMA Boxes Options Description

Units equipped with angle brackets (AB) option may be enclosed in NEMA boxes to ensure protection against harsh environments that may be damaging to the unit. Four configurations are available for this purpose.

Oil Tight (OT) NEMA Box Option. This enclosure consists of a NEMA12 box construction, with two

cover-holding screw clamps, mounted opposite to the hinged side of the cover (right side). These enclosures are oil and dust tight only. Conduit holes, fittings, or knockouts are not provided on these boxes. Suggested fittings are "Myer's Scrutite." The units are mounted on a drilled and tapped mounting plate at the back of the box.

Water Tight (WT) NEMA Box Option. This enclosure consists of a NEMA4 box construction equipped with three cover-holding screw clamps, one on each of the three non-hinged sides of the box. These enclosures are watertight, in addition to oil and dust tight. Unit mounting and electrical connections are made in the same manner as the OT option enclosures.

General Purpose (GP) Options Enclosures. This enclosure consists of a general purpose steel construction box with knock-outs for various size electrical conduits ($\frac{1}{2}$, $\frac{3}{4}$, or 1 inch). The cover is hinged and spring locked. Units are secured into the enclosure on four studs and four 10-32 nuts. The complete enclosure can be secured through four mounting holes provided on the box-back cover.



Unit in Water Tight (WT) Enclosure

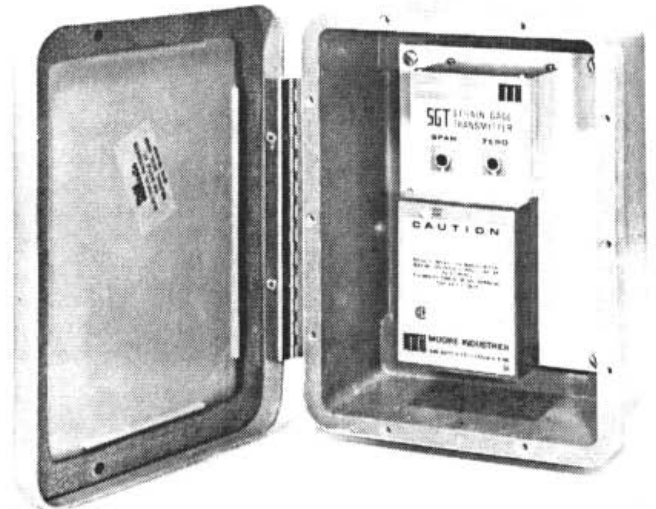

Corrosion Resistant Fiber Glass (FG) Enclosure

Fiber Glass (FG) Option Enclosures. This enclosure is molded from pigmented polyester resins, using 302 stainless steel for all exposed hardware. A one-piece neoprene jacket provides additional sealing protection against corrosive environments. Boxes are normally hinged on the long side. The cover is secured by four slot-head screws accessible at the top of the cover and located on each side of the top and bottom cover corners opposite the hinge side. Conduit holes may be cut with a hole punch, and special precautions must be taken with ground connections, since the box material is non-conductive. Refer to Section 3 for wiring information. Units are mounted into the enclosure in the same way as in the OT enclosures.

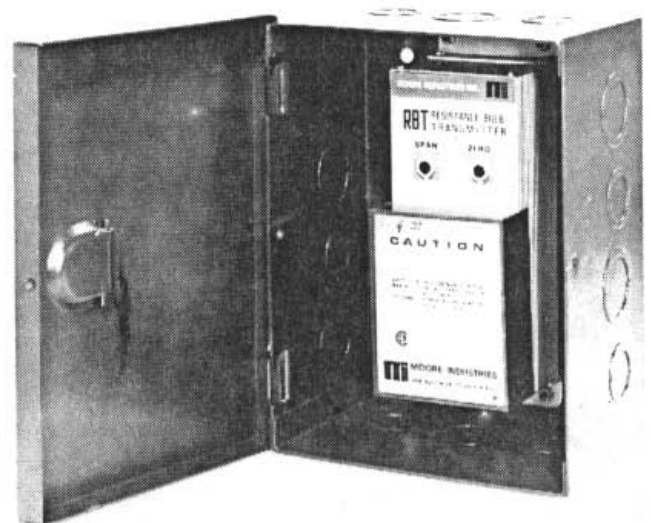

General Purpose (GP) Enclosure

1.3.4 RAA and RAT Options Description

These options consist of special mounting hardware attached to MOORE units to replace obsolete instrumentation of other manufacture.



Replacement Mounting (RAA Option)

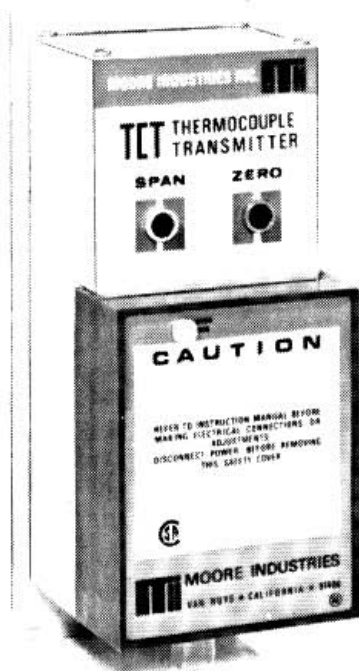

Replacement Mounting (RAT Option)

1.3.5 Standard Plug-In Transmitter (PA and PST) Options

The standard plug-in transmitter consists of a standard enclosure as described in paragraph 1.3 except that connections are not provided on the face of the unit. Instead, the transmitter is attached physically and electrically to a circular interconnect card with plug-in pins, keyed to eliminate errors in connections. The mating connector consists of a bracket-mounted square terminal block. External electrical connections are made to screw terminals located on the periphery of the connector block. A plug-in receptacle arrangement is located in the center of the block to accommodate the keyed interconnect card plug-in pins from the transmitter. The mounting bracket secured to the terminal block is pre-drilled with clearance holes for 10-32 screws. When the transmitter assembly is removed, the terminal block screw connections are easily accessible.

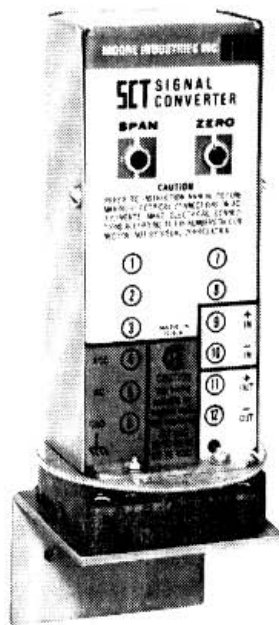

Plug-In Standard Unit (PST)

1.3.6 Explosion Proof (EXT, EXC & EXX) Option

The explosion-proof enclosure option consists of a PST option unit described in paragraph 1.3.5 enclosed into a two-piece cast aluminum alloy enclosure. The two pieces consist of a screw-type

block is secured flush with the bottom of the housing. Electrical conduit hubs are provided for external electrical wiring through electrical conduits. Several configurations of conduit inputs are available. Refer to Section 3 for detailed description of conduit configurations.



Explosion Proof Housing (EXC Shown Only)

1.3.5 Panel Mounted Transmitter (PM) Option

This option is electrically similar to the unit of paragraph 1.3, except that the enclosure and terminals locations are different. Instead of the standard enclosure, the printed circuit boards are enclosed in a metal frame equipped with a blank panel. Controls and electrical connections are accessible to the rear of the enclosure by removing a cover. The bottom of the frame is provided with two holes to accommodate 1/2-inch electrical conduit.

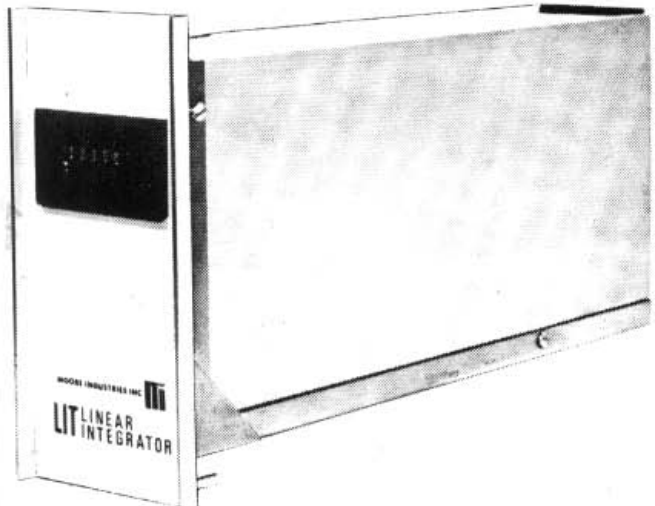

Panel Mounted Unit (PM)

1.4 SPECIFICATIONS

The specifications for the unit are listed in Table 1-1.

1.5 MODEL NUMBER EXPLANATION AND USE

MOORE INDUSTRIES' model numbers describe an instrument's type, functional characteristics, operating parameter, and include option identification. If all accompanying documentation of a unit is missing, the model number may be used to obtain technical information on the unit by following the example of Table 1-2. The model number for standard units, and units with CP and AB options, is located at the upper end of the terminal block stamped on a stainless steel tag. Plug-in units have their model number labeled on the inside of the grip extension to the front panel. PST units have the model number on top of the transmitter case. For explosion-proof units, the model number is stamped on a stainless steel tag on top of the enclosure and on the identification label on the unit within the enclosure. PM units model numbers are stamped on a stainless steel tag, visible when the rear safety cover is removed. To expose the model number on all NEMA box enclosures, open box and remove safety cover of the unit.

1.6 SERIAL NUMBER USE AND LOCATION

A complete history is kept on every MOORE unit. This information is keyed to the serial number. Whenever service data is required on a unit, it is necessary to provide the factory with a serial number as well as a model number. This identification is usually located with the model number (see paragraph 1.5 for location on equipment).

168-701-00B FSM FREQUENCY SCALING MODULE

INPUT:

Frequency: 20 KHz, max sine or square wave
 Sensitivity: 100 mV to 25 V P/P
 Input Impedance: Greater than 5K ohms resistive

Effect: No change in output over above temperature range

Isolation: Isolation between power and input-output is standard. Input-output isolation is achieved by specifying -RR option.

OUTPUT: 24V, 30 msec pulse compatible with external standard electromechanical totalizer at a rate equal to input frequency (F_1) multiplied by the scaling factor (K). $F_o = F_1 \times K$. Optional SPDT relay contact output (-RR option).

Scaling Range: Multiplies input frequency by an adjustable factor of 0 through 0.999999.

POWER INPUT:

24V DC, 45V DC, $\pm 10\%$ standard
 117V AC, 220V AC, 240V AC, 50/60 Hz, $\pm 10\%$ optional
 5 watts nominal

PERFORMANCE:

Calibration Capability: ± 1 input pulse

Ambient Temperature:

Range: 0°F to +165°F (-18°C to +74°C)

Line Voltage Effect: AC or DC: No change in output over above line voltage range.

WEIGHT: Approximately 2 lbs. (908 grams)

TABLE 1-2. MODEL NUMBER EXAMPLE

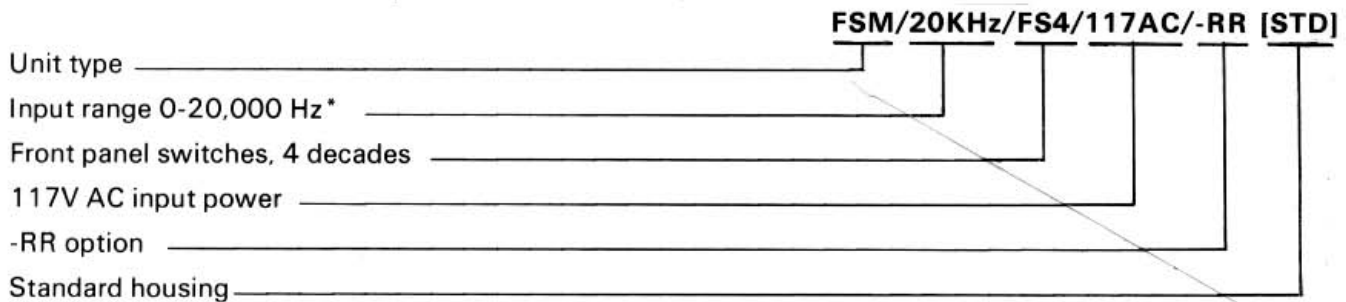

* Required input for model without AO option

TABLE 1-3. FSM ELECTRICAL OPTIONS

OPTION DESCRIPTION	CODE
Analog output = Output range 1-5 mA, 4-20 mA, 10-50mA, 1-5V, 0-5V, 0-10V (specify output range) (Requires [PM] housing)	AO
Auxiliary pulse + 12V at 10 microseconds or 30 msec for electronic totalizers (specify pulse width)	AP
Input attenuation for input voltage exceeding specification	AT
Contact closure input	CC
Frequency doubling. If output is IS5, then multiplier of frequency available is 0 thru 1,9999	FD
Front mounted totalizer for FSM, other than MF5043-6 which is standard for [PM] housing	FT
Integral totalizer, six digits. Must specify [TE], [TS], or [NB] housing	IT
No totalizer. [PM] housing only	NT
Excitation for 3-wire turbine meter pre-amps (+12V at 10 mA maximum)	PX
Excitation for 2-wire turbine meter pre-amps (+12V at 10 mA maximum). To be used with MII FFX unit or other 2-wire type pre-amplifiers.	PXI
Internal SPDT relay contact output 1A at 28V DC non-inductive	RR

TABLE 1-4. ADDITIONAL SPECIFICATIONS FOR AO OPTION

INPUT:

Input Impedance: Greater than 5000 ohms, 100 mV to 25V P/P

Input Ranges: Ranges listed are the minimum and maximum inputs to produce full scale output
 0 to 50 thru 100 Hz (See LF option)
 0 to 2.5 thru 50 Hz (See LF option)

TERMINAL PANEL ADJUSTMENTS: Adjustable with multiturn potentiometer

Span: Output fully adjustable over a preselected input range to 100% of selected output span

Zero: With minimum input, adjusts output to 0% \pm 10% of selected output span

OUTPUT: Operational amplifier feedback current source; output limited to 150% of maximum output range value

Current:

- 1-5 mA into 0-4800 ohm load
- 4-20 mA into 0-1200 ohm load
- 10-50 mA into 0-480 ohm load

Voltage: 1-5 VDC standard into 20K ohms minimum
Ripple: 10 mV P/P at maximum span and maximum load resistance

Load Effect: \pm 0.01% of span from 0 to maximum load resistance (current output)

PERFORMANCE:

Calibration Capability: \pm 0.05% of span (linearity and repeatability)

Ambient Temperature:

Range: 0°F to +165°F (-18°C to +74°C)
 Effect: \pm 0.005%/°F over above range

Isolation: Isolation between power and input-output is standard. Input-output isolation is achieved by specifying II option.

POWER INPUT:

24 VDC, 45 VDC, \pm 10% standard
 117 VAC, 240 VAC, 50/60 Hz \pm 10% optional
 5 watts nominal

Line Voltage Effect: AC or DC: \pm 0.005%/1% line change

WEIGHT: Approximately 4 lbs. (1.8 kilograms)

TABLE 1-5. AO OPTION, MODEL NUMBER EXAMPLE

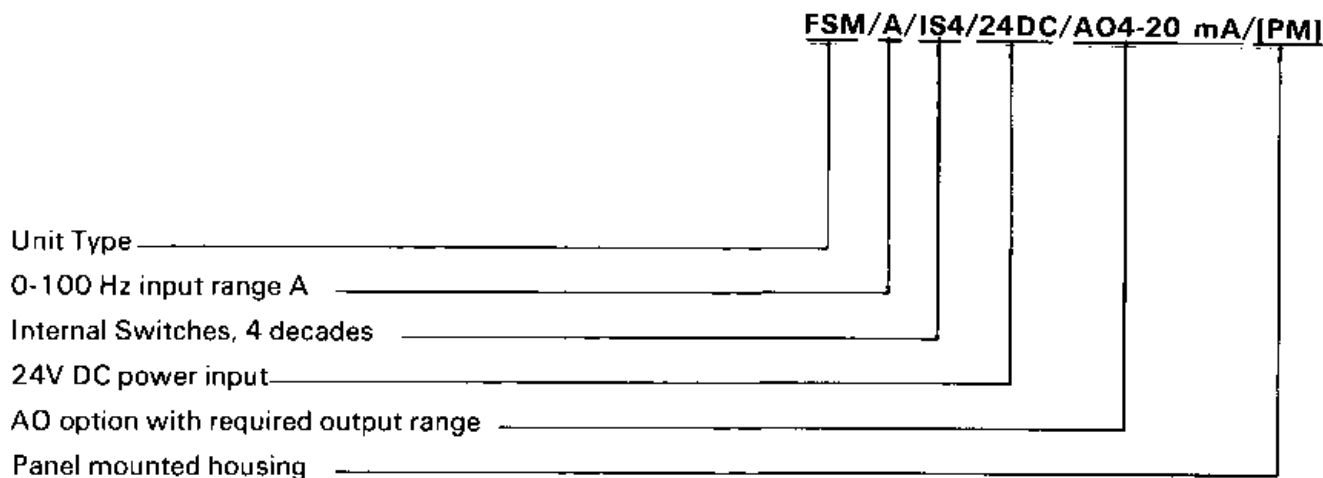

TABLE 1-6. ADDITIONAL OPTIONS AVAILABLE WITH AO OPTION

OPTION DESCRIPTION	CODE
Zero elevation for inputs exceeding standard zero adjustment capability (specify input for 0% out)	EZ
Front mounted meter for FSM	FM
High current (20 mA) 1-5V DC output	HI
Transformer coupled input (300 mV to 20V P/P)	II
Frequencies from 2.5 Hz to 50 Hz, specify maximum frequency (includes factory calibration)	LF

CALIBRATION PROCEDURES

2.1 GENERAL INFORMATION

This section provides information about unit calibration. Units with standard input and output levels are normally calibrated at the factory. After the unit is unpacked, general operating level checks of units are recommended. Usually these checks, specified in this section under calibration procedures, require little or no adjustments. If units are ordered with factory calibration option (FC), an exact calibration is performed at the factory, and red caps are placed on the controls. Adjustments should not be made in the field on these units unless a new range of input or output signal level is desired. Red caps should not be removed as a precaution against accidental adjustments.

2.2 CONTROLS DESCRIPTION AND LOCATION

The controls for setting the scaling factor are thumbwheel switches which are located on the front panel for standard units. These can be mounted either on the front panel or internally if the PM housing is selected.

If the AO option is specified, two additional controls are mounted to the terminal panel on the PM housing. These are the ZERO and SPAN adjustments which are multiturn potentiometers that are adjusted with a blade screwdriver NOT MORE THAN 0.1 INCH (2.54 mm) WIDE. USE OF A WIDER BLADE MAY PERMANENTLY DAMAGE THE POTENTIOMETER MOUNTING. This type of potentiometer usually requires 20 turns of the shaft to move the wiper from one end of its range to the other. It is equipped with a slip clutch at either end of its travel to prevent damage if it is turned beyond the wiper stop. Usually a slight change in feel will be noticed when the clutch is slipping. However, if this change is not observed, either end can be reached by turning the shaft 20 turns in the desired direction. Controls are connected, so turning the shaft clockwise increases the quantity or makes it more positive, and turning the shaft counterclockwise has the opposite effect.

2.3 TEST EQUIPMENT AND TOOLS REQUIRED

Test equipment and tools required for calibration of the unit are described in Table 2-1; they are not supplied and must be provided by the customer at the installation or test site.

TABLE 2-1. TEST EQUIPMENT AND TOOLS REQUIRED

Equipment or Tool	Characteristic	Purpose
Screwdriver (blade)	Blade not wider than 0.1 inch (2.54 mm)	Front panel control adjustment
Audio Frequency Signal Generator	Must be capable of producing signal ranges defined by INPUT level requirements of purchased unit (see Table 1-1)	Simulate input signal levels
DC Voltmeter	Must be accurate to within $\pm 0.025\%$ or better	Output signal monitoring (voltage outputs only) ⁶
DC Milliammeter	Must be accurate to within $\pm 0.025\%$ or better	Output signal monitoring (current outputs only)
Frequency Counter	Must be accurate to within $\pm 0.025\%$ or better	Input signal monitoring

2.4 TEST EQUIPMENT SETUPS

Off-line calibration for all units require the same test equipment setups regardless of option or physical configuration. The hookup requirements and physical preparations may vary on some units. The following paragraphs define the general test setup and identify the units that require special attention for test preparation and connections.

The test equipment setup required for calibration of all units is identical except for connection identification. Figure 2-1 shows the general test setup configuration. Connection nomenclature refer to terminal markings on the standard units with CP, AB, RAA/RAT, PM, and NEMA boxes mechanical options.

2.5 CALIBRATION OF UNITS WITHOUT AO OPTION

Units are calibrated and checked for proper performance at the factory before they are shipped. However, unless calibration was requested to a specific set of input-output values, the unit performance should be checked by the user before the unit is placed in service. To check the operation of the unit, proceed as follows:

- Connect the unit and test equipment as shown in Figure 2-1.
- Apply power input to the unit.
- Set the thumbwheel switches to the desired scaling factor.
- Apply an input frequency from the signal generator that is the maximum frequency that will be applied to the unit when it is installed. (Note: If an accurate and stable frequency source is used, such as a frequency synthesizer, monitoring the input with a frequency counter is not necessary.)
- Monitor the pulse output terminals with a frequency counter and verify the output frequency equals the input frequency multiplied by the scaling factor.

2.6 CALIBRATION OF UNITS WITH AP OPTION

The operation of a unit with an AP option should be checked in the same manner as outlined in paragraph 2.5 except that the output frequency at the \pm AP terminals should also be monitored.

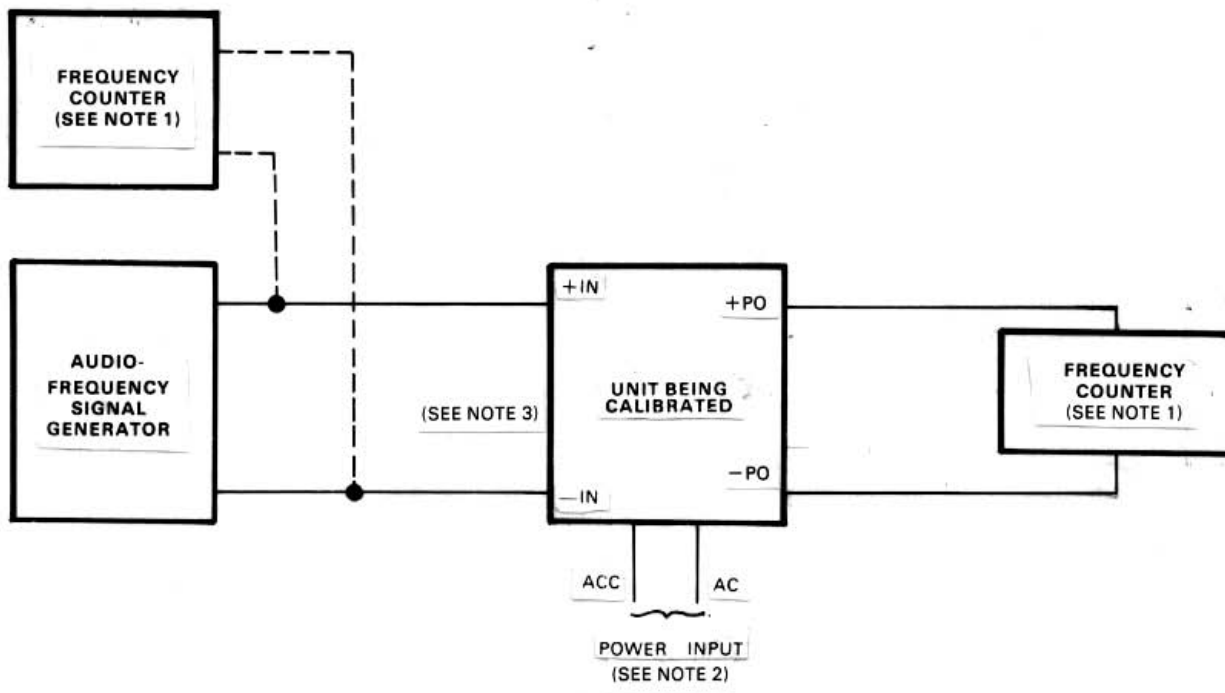

NOTES:

- Input and output monitoring devices must be accurate to within $\pm 0.025\%$ or better.
- Either AC power or DC power is supplied, but not both.
- Input signal amplitude must be greater than 100 mV but less than 25V P/P.

Figure 2-1. Test Equipment Setup For Calibration of Units Without AO Option

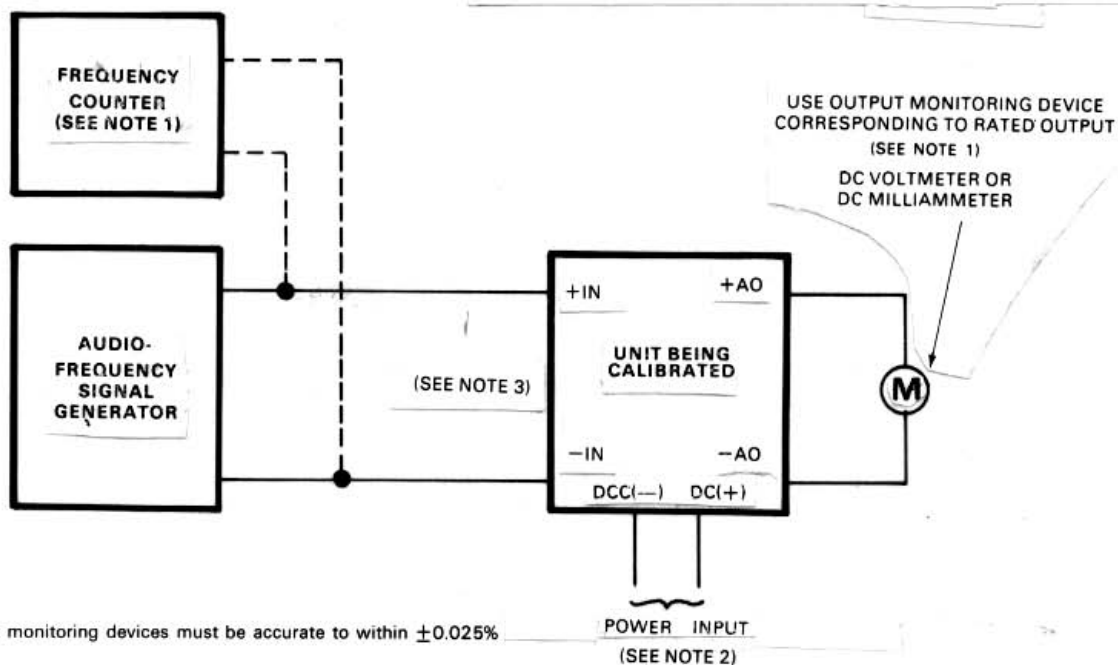

NOTES:

1. Input and output monitoring devices must be accurate to within $\pm 0.025\%$ better.
2. Either AC power or DC power but not both.
3. Input signal amplitude must be greater than 100 mV but less than 25V P/P.

Figure 2-2. Test Equipment Setup for Calibration of Units with AO Option

2.7 CALIBRATION OF UNITS WITH AO OPTION

Calibration of units with the AO option consists of simulating the operative signal input and adjusting the unit to obtain the specified output.

NOTE

Adjustments should *not* be made in the field on units that are calibrated to values specified in the purchase order. Units that are calibrated at the factory to customer's specifications have protective caps over the SPAN and ZERO potentiometers; do NOT remove these caps.

An audio-frequency signal generator with a range covering the frequencies with which the unit will be used and an output monitoring device are required for calibration. A frequency counter to determine the frequency of the applied input signal to the required accuracy is not needed if an accurate and stable frequency source is used (e.g. a frequency synthesizer or equivalent). The monitoring device (current or voltage) must have an accuracy of within 0.025% or better.

NOTE

Refer to paragraph 1.5 for information on how to use the model number to determine the frequency range of the input signal and to obtain the specified values of minimum and maximum output.

To calibrate a unit, proceed as follows:

- a. Connect unit and test equipment as shown in Figure 2-1 or 2-2, except temporarily leave the signal generator disconnected from the unit and short circuit the input terminals of the unit.
2. Apply power input to the unit.
- c. With the input terminals of the unit shorted, adjust the ZERO potentiometer to obtain 0% output from the unit (1 mA, 4 mA, 10 mA, 1 VDC, or whatever the 0% output will be).
- d. Remove the short circuit from the input terminals of the unit and connect the signal generator to these terminals. Adjust the signal generator to the maximum frequency

2.9 CONNECTION INFORMATION FOR FSM WITH PXI AND AO OPTIONS

When the FSM is supplied with PXI and AO op-

tions connect the equipment as shown in Figure 2-4. The +PXI terminal is +12V power to a 2-wire type pre-amp and the -PXI terminal detects the current signal from the pre-amp.

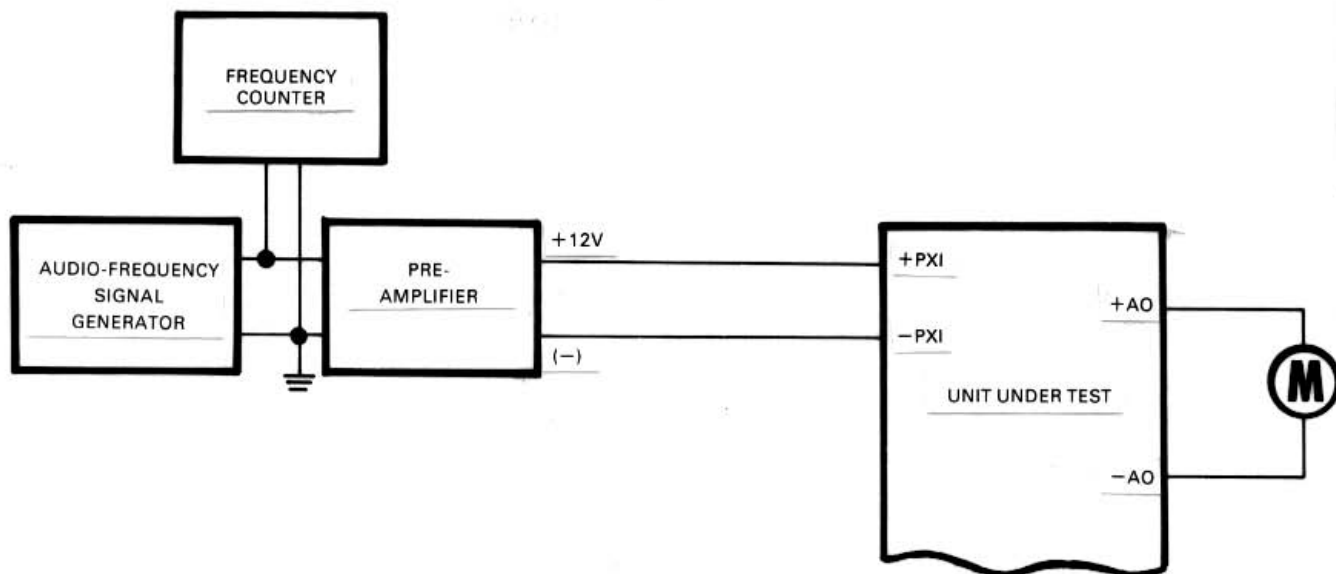
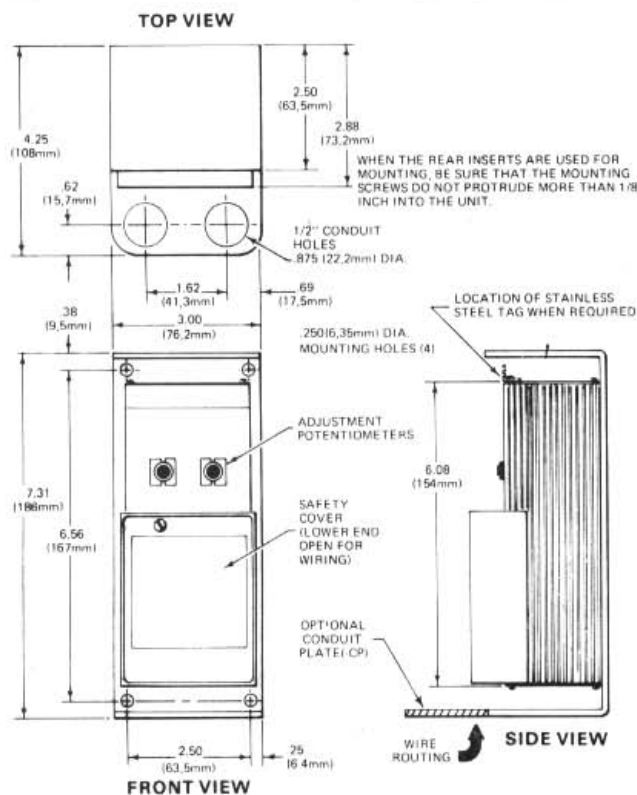

Figure 2-4. Test Equipment Setup for Calibration of Unit with PXI and AO Options

INSTALLATION & OPERATION

3.1 MECHANICAL INSTALLATION

Units may be obtained in various physical configurations. Figures 3-1 through 3-8 show the outline dimensions and other installation requirements for the available configurations. Since all MOORE units use the same casing, a standard unit is shown in the following illustrations. Select the proper outline and dimension figure applicable to the unit purchased. Be sure to observe the applicable special procedures and precautions given with the illustration. Although the units are designed to operate in free air at quite a high ambient temperature, it is advisable, if possible, to mount the unit on a surface made of material that can serve as a heat sink.



NOTES:

1. Complete Model No. and Serial No. are permanently marked on identification plate located at upper end of terminal blocks
2. When extra-compact mounting is required for rack or portable installation, C-shaped mounting bracket may be removed and two threaded inserts (located 4.00 inches apart) may be used for mounting, using 6-32NC machine screws.

Figure 3-1. Standard Unit and Unit with CP Option, Outline and Dimensions

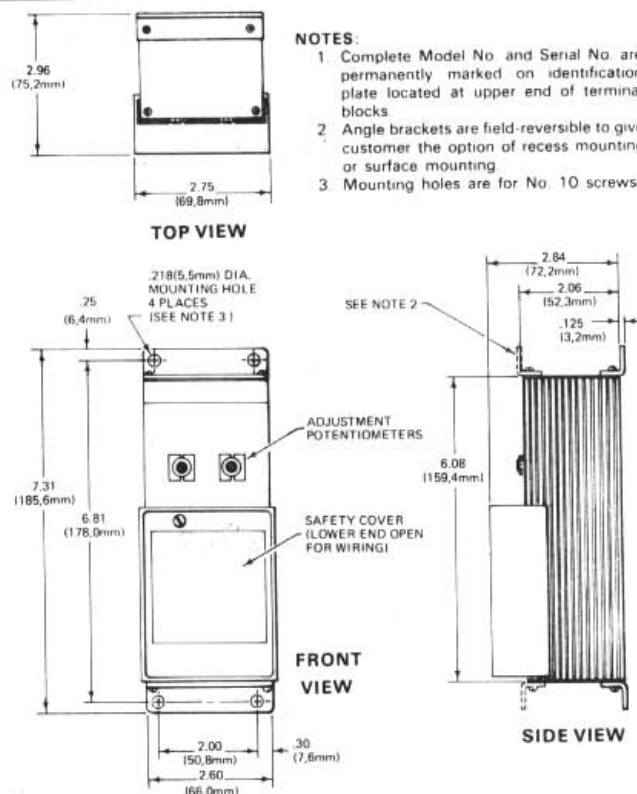

NOTES:

1. Complete Model No. and Serial No. are permanently marked on identification plate located at upper end of terminal blocks
2. Angle brackets are field-reversible to give customer the option of recess mounting or surface mounting
3. Mounting holes are for No. 10 screws.

Figure 3-2. Standard Unit With Angle Brackets (AB) Option, Outline and Dimensions

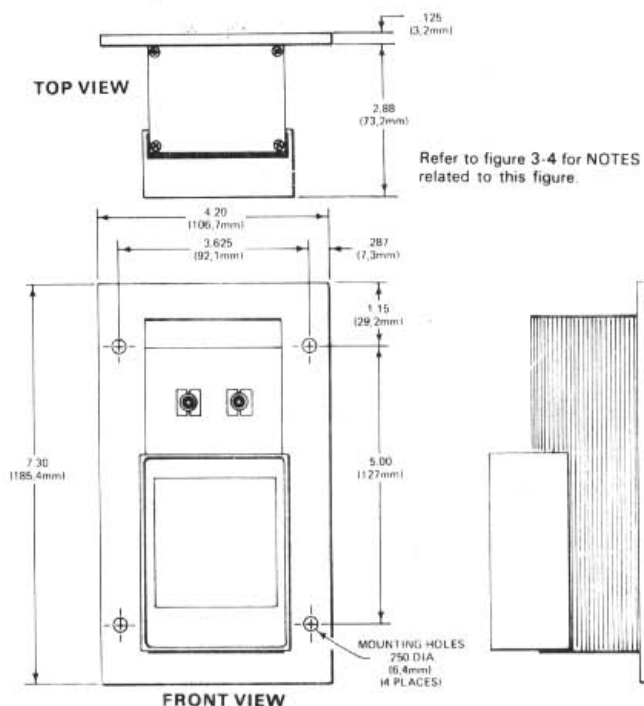
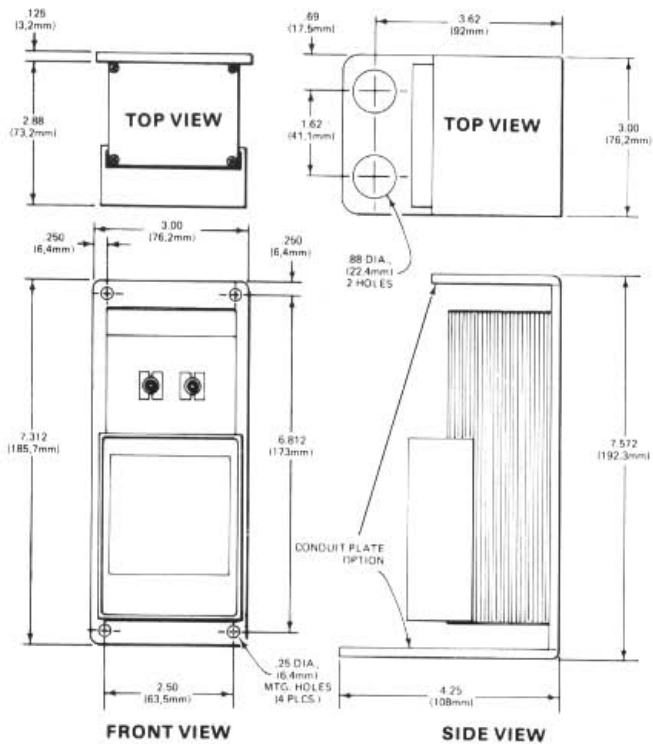

Figure 3-3. Standard Unit With Adaptor Plate (RAA) Option, Outline and Dimensions



NOTES:

1. Use two threaded inserts (located 4.00 inches apart on back of standard transmitter) for mounting adapter plate to transmitter. Use 6-32 NC machine screws.
2. Unit to adapter plate mounting screws should not protrude more than $\frac{1}{8}$ " into the unit.

Figure 3-4. Standard Unit, With Adapter Plate (RAT) Option, Outline and Dimensions

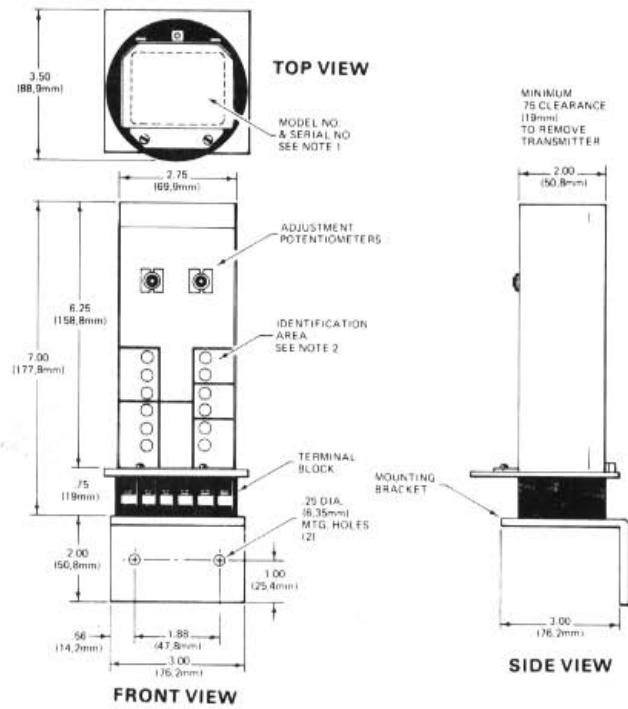

NOTES:

1. Identification area on top of unit case carries complete model number and serial number.
2. Identification area on front of transmitter case gives electrical connection information.

Figure 3-5. Standard Unit With Plug-In STD Transmitter (PST) Option, Outline and Dimensions

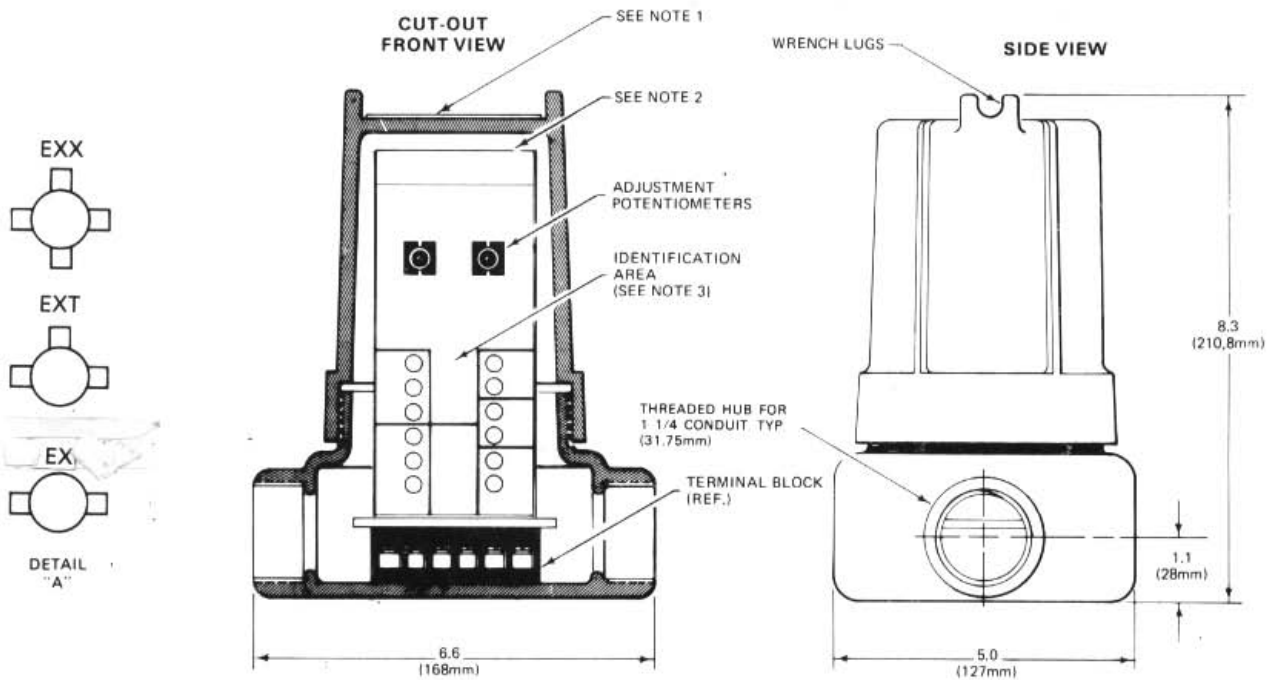

NOTES:

1. Top of cover has metal label carrying unit type (e.g. TCT, MVT) and equipment number (if any).
2. Identification area on top of unit case carries complete model number and serial number.
3. Identification area on front of unit case gives electrical connection information.
4. "EX" housing (two conduit hubs) is shown above. Similar housings with three or four hubs is illustrated in detail A. Housings are cast aluminum alloy and meet NEMA specifications for Class I, Groups C and D and Class II, Groups E, F, and G.

Figure 3-6. Standard Unit in Explosion-Proof Enclosure, Outline and Dimensions

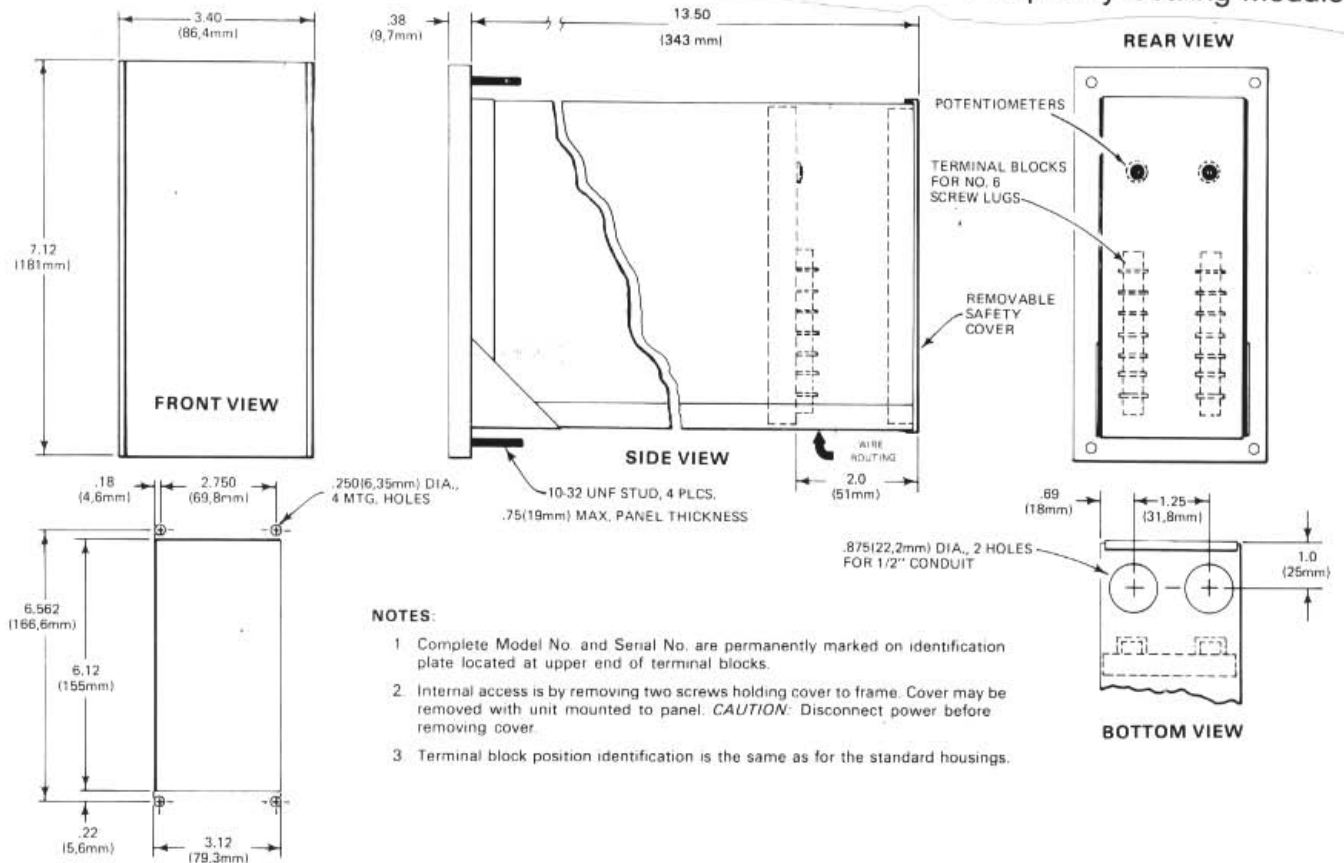
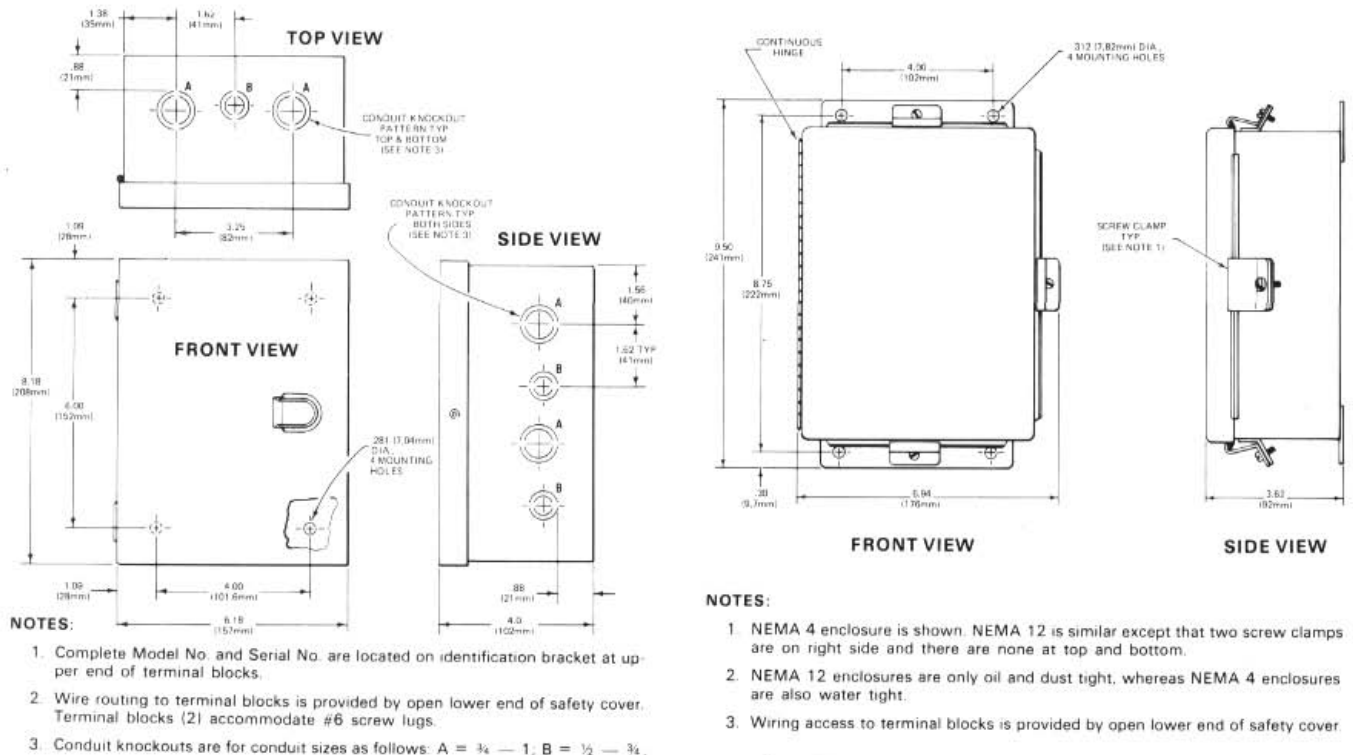

Figure 3-7. Standard Unit with Panel Mount Enclosure (PM) Option, Outline and Dimensions



a. General Purpose (GP) Enclosure

b. Water and Oil-Tight (WT/OT) Enclosures

Figure 3-8. Standard Unit in NEMA Boxes, Outline and Dimensions

FRONT VIEW

SIDE VIEW

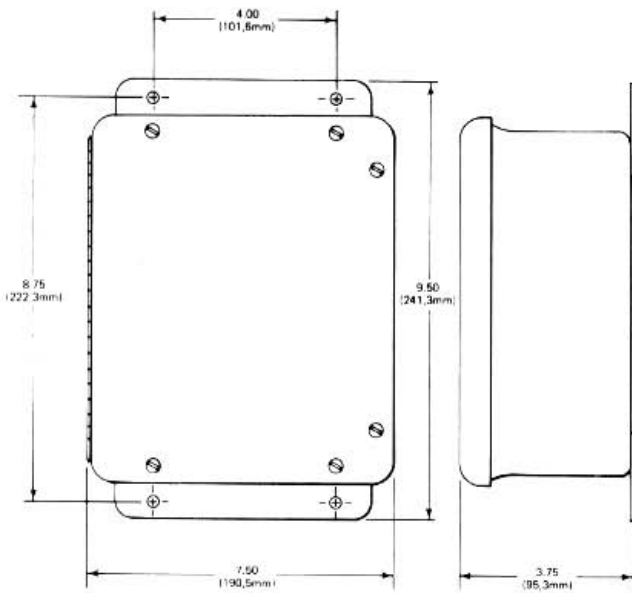

NOTES:

- 1 All exposed metal hardware is type 302 stainless steel. Boxes are hinged on the long side unless otherwise specified.
- 2 All boxes include a one piece closed cell neoprene gasket.
- 3 Standard color is machine tool grey. Boxes are molded from pigmented polyester resins with the color throughout the box wall for a maintenance-free installation.

c. Corrosion-Proof (FG) Enclosure)

Figure 3-8. Standard Unit in NEMA Boxes, Outline and Dimensions (Cont.)

3.2 ELECTRICAL CONNECTIONS

All electrical connections to standard units are made to the terminal blocks on the unit. Terminals used for standard units and their options are defined in the following paragraph.

3.2.1 General Wiring Information

No special wire or cable is required for signal connections to the unit. To avoid transients and stray pickups, it is recommended that twisted conductors be used where they are run close to other services (such as power wiring).

Wiring Information for All Standard Units With Terminal Strips and Blocks. Standard units with terminal strips or terminal blocks have terminals supplied with 6-32 screws long enough to easily accommodate three spade-lug connectors. Standard units with snap-off plastic covers have an opening in the bottom of the cover. Dress all wiring to and from the terminals through this opening. Spade lug connectors are recommended for all wire terminations.

3.2.2 Signal Connections

Figure 3-9 illustrates the terminal strip locations and identification for the standard units and the terminal block identifications for the explosion proof and PST configurations. Figure 3-10 illustrates the terminal strip locations and identification for units in the PM housing.

Tables 3-1 and 3-2 provide the complete labeling nomenclature for all available electrical options for a standard FSM and FSM in a PM housing, respectively. Terminal labeling appears next to the terminal it identifies on standard and PM units. For PST and explosion-proof units, terminal labeling is marked on the front of the unit housing with the referenced terminals identified numerically.

Wiring Information for All Units in NEMA Boxes. Units mounted in NEMA boxes are standard units with or without the options listed in Table 3-1. NEMA boxes for OT or WT options do not have conduit holes fittings or knockouts. Conduit access must be provided by fittings such as Myer Scru-Tite or equivalent.

General Purpose (GP) enclosures have conduit knockouts for various sizes of conduits from 1-inch down to 1/2-inch. Corrosion-Proof (FG) enclosures require special attention with ground connections. Since enclosure material is polyester resin, conduit cutouts may be cut with a punch or hole saw. Ground continuity may be obtained in two different ways. If a metal panel is used, ground can be made between the metal conduit locknut and the panel at enclosure entry and exit. If the enclosure is used without the back panel, a jumper between the conduit entry and exit is necessary to maintain ground continuity. Remove snap-off plastic cover to access terminal strips.

3.2.3 Power Connections

Units are designed to operate from either a DC or AC power source. Refer to paragraph 1.5 for information on how to use the model number to determine the type of power required.

DC-Powered Units. On these units the DC terminal is connected to the + (positive) side of the source, and the DCC terminal is connected to the - (negative) side. The DC source should be regulated to within ±10% of the nominal voltage and should be capable of delivering 5 watts.

AC-Powered Units. These units require 117 volts AC ±10%, 50/60 Hz at 5 VA of nominal power or

220 or 240V AC optionally. The AC terminal should be connected to the ungrounded or "hot" side of the supply, if possible, and the ACC ter-

minal is connected to the common or neutral. The GND terminal is the mechanical case connection.

IDENTIFICATION BRACKET WITH COMPLETE MODEL NUMBER AND SERIAL NUMBER

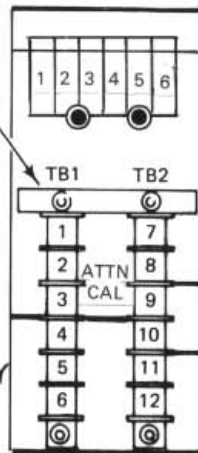

REFER TO TABLE 3-1 FOR NOMENCLATURE

IDENTIFICATION IS ON OUTBOARD SIDE OF TERMINAL BLOCKS

12 POSITION TERMINAL BLOCK AND CONNECTOR (FOR NO. 6 SCREW LUGS)

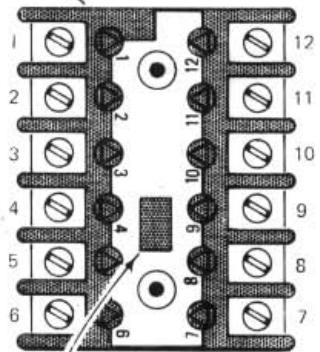

KEYWAY

a. Standard Units

b. Units with EX or PST Configuration

Figure 3-9. Terminal Strips and Terminal Blocks Identification

TABLE 3-1. TERMINAL NOMENCLATURE — STANDARD HOUSING

Options (See Note 1)	Terminal Positions											
	1	2	3	4	5	6	7	8	9	10	11	12
DC POWER NO OPTIONS				(-) DCC	(+) DC	GND			(+) IN	(-) IN	(+) PO	(-) PO
AC POWER NO OPTIONS				ACC	AC	GND			(+) IN	(-) IN	(+) PO	(-) PO
RR	NO	CM	NC									
PX							(+) PX		(+) IN	(-) IN		
PXI									(+) PXI	(-) PXI		
AP							(+) AP	(-) AP				
CC (SEE NOTE 2)												

Legend:

NO	Normally Open	± PO	Pulse Output (+24V)
CM	Common	± AP	Scaled Output (+12V)
NC	Normally Closed	± IN	Signal Input
DC	+DC Power Input	AC	AC Power Input
DCC	-DC Power Input	ACC	AC Power Return
GND	Chassis Ground	+ PX	+12V Excitation Output
CC	Contact Closure	+ PXI	12V Excitation Output
		- PXI	Current Signal Input

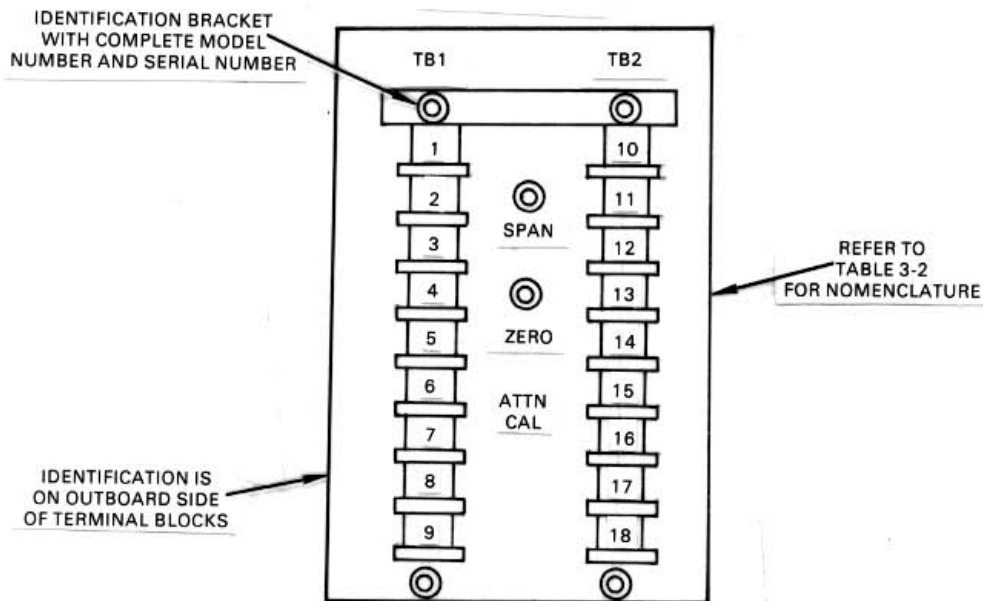

Figure 3-10. Terminal Strips and Terminal Blocks Identification for Units in PM Housing

TABLE 3-2. TERMINAL NOMENCLATURE — PM HOUSING

Options (See Note 1)	Terminal Positions																	
	1	2	3	4	5	6	7	8	9	10	11	12	13	14	15	16	17	18
DC POWER NO OPTIONS	(+) IN	(-) IN					(-) DCC	(+) DC	GND								(+) PO	(-) PO
AC POWER NO OPTIONS	(+) IN	(-) IN					ACC	AC	GND									
RR				NO	COM	NC												
PX	(+) IN	(-) IN	(+) PX															
PXI											(+) PXI	(-) PXI						
AP												(+) AP	(-) AP					
AO															(+) AO	(-) AO		
CC (SEE NOTE 2)																		

Legend: \pm AO = Analog Output

NOTES:

1. Labeling shown here may be combined. The combination may include standard labeling and one or more options. Combinations of options may cause labeling positions to change, but nomenclature will remain as shown.
2. Terminal nomenclature not affected by this option. CC connections made across +IN and -IN terminals.

3.3 OPERATION AND PERIODIC OBSERVATION

Once calibrated and installed, the unit may be operated unattended. The only controls on the outside of the unit are the decade switches, and if AO option is specified, SPAN and ZERO potentiometers, which, after initial adjustments, need no further attention. There are no indicators on the unit. Because the circuit uses highly reliable solid-state components with no moving parts, the unit should operate virtually maintenance-free for a

long period of time. However, if a malfunction should occur, refer to Section 5 for maintenance information.

A periodic check of input and output connections is recommended every six months to ensure continued dependability of operation.

A unit may become warm during operation, especially where the ambient temperature is rather high. This is perfectly normal and should not be a cause for alarm unless a malfunction is also observed.

THEORY OF OPERATION

4.1 INTRODUCTION

This section describes the unit operation. An overall view of the unit function based on the block diagram of Figure 4-1 introduces the user to the unit functional elements. This functional analysis is further detailed in the circuit description paragraphs that follow. Each of these paragraphs also contains a detailed description of the circuit operation. These descriptions are based on the schematic diagram included in Section 6, Unit Documentation.

Sheet 1 of the schematic contains the circuitry required for frequency scaling and is described in detail in paragraph 4-2. Sheet 2 of the schematic is dedicated to the AO option (analog output) and this circuitry is described in paragraph 4-3.

4.2 FREQUENCY SCALING

4.2.1 Functional Description

The FSM consists of a wave-shaping circuit, manually controlled rate multipliers, some selection logic and a one-shot with output circuits. Figure 4-1 shows the FSM circuits in a functional form.

The input waveform is shaped into a suitable clock signal by the input circuits and buffered into the rate multipliers and the logic circuits. The rate multipliers consist of manually controlled cascading frequency dividers. Scaling factor selection is effected manually by thumbwheel switches. Each rate multiplier is capable of multiplying by 0 thru 0.9. The ultimate result if all the stages have been selected is a 0 thru 0.999999 multiplication of the input frequency.

The logic circuits select the combination of the wave-shaped input signal and the output of the rate multipliers. These signals are then ORed together and capacitively coupled into a one-shot circuit that develops a 30 msec pulse for each cycle of the incoming frequency. This pulse is then amplified by the output drivers.

4.2.2 Power Inverter Circuit

NOTE

The following description uses reference designators that apply to the Power Inverter Circuit, drawing 400-404-00 only. They are not to be confused with the reference designations of PCI.

The power inverter is a transformer-coupled multivibrator oscillating at approximately a 3 KHz rate. Because the core of the transformer is saturated, a square wave of reasonably instant amplitude is generated. This signal can be observed at the collector of Q1 or Q2. The transformer has four secondary windings isolated from each other. Only two of these are used to produce independent square wave outputs. These outputs instead of the outputs from the AC power supply, are then applied to the rectifiers and regulators which function in the usual manner. A diode in the DC (positive) lead will prevent damage to components in the power inverter if the DC primary source is accidentally connected with incorrect polarity.

The components of the power inverter are mounted on a printed circuit board attached to the main board for standard units. Drawing 400-404-00 is the schematic diagram of the power inverter (PCA) used on a standard unit. When a standard unit is ordered for use with DC power, the power inverter is used instead of the AC source T1 shown on the unit schematic diagram. The DC applied to the power inverter is converted to a square wave of approximately 3 KHz by Q1, Q2, and the primaries of T1, functioning as a DC-to-AC inverter. Filter L1-C4 prevents the 3-KHz signal from getting back into the external DC source. CR1 provides protection against damage from inadvertent application of DC of incorrect polarity. The square-wave output from center-tapped secondary 8-13 is applied to CR5 thru CR8, and that from secondary 17-16 is applied to rectifiers CR2, CR3, CR9, CR10.

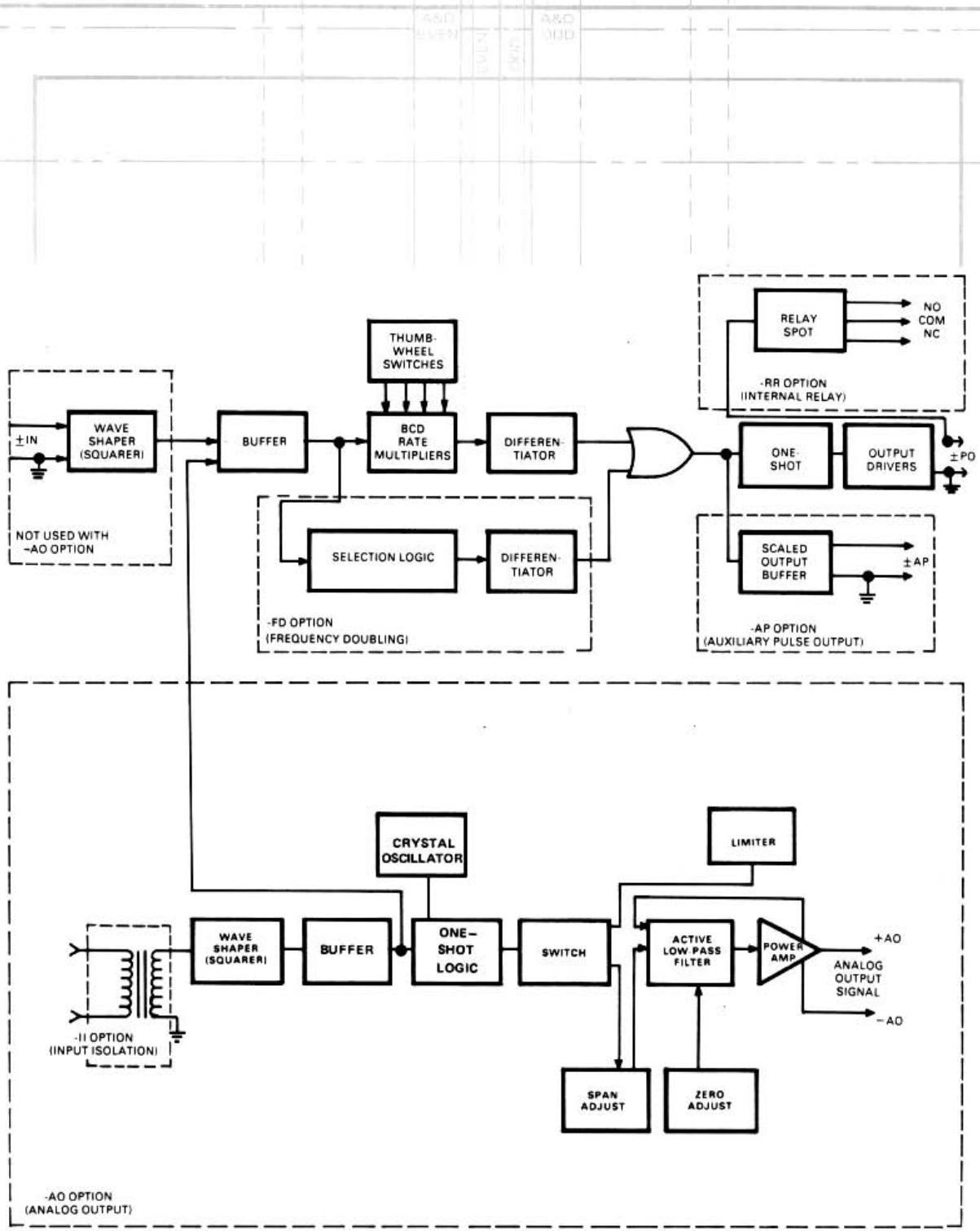

Figure 4-1. FSM Block Diagram

4.2.3 Description of AC Power Supply Circuit

The AC power supply consists of rectifiers, regulators and filters. The ± 12 volt supplies are generated from the center-tapped output of PCA or T1 ORN/YEL/GRN leads. This signal is full-wave rectified by CR5 thru CR8 and filtered by C3, C7. Regulation is affected by two three-terminal regulators VR2 and VR3.

The +24V supply is generated from the high voltage (BLU/VIO) output, outputs from PCA or T1. The signal is full wave rectified by CR2, CR3, CR9 and CR10 and filtered by C8. A pre-regulator circuit consisting of Q1, Q4, Q5 and associated components, assist VR1 in the fairly high current regulation. This combination holds a consistent regulation at about 30 volts at the input to VR1. Zener CR1 prevents lock-up if power is set to on at full load. Capacitor C4 provides the output filtering, while VR1 regulates the supply to 24V DC.

4.2.4 Input Circuit

The standard input circuit consists of an integrator, a voltage comparator, and input buffers. The input is thus processed to provide suitable triggering signals for the rate multipliers.

The input circuit consists of an integrator and a voltage comparator used as a signal level modifier and input buffers. The input is thus processed to provide suitable triggering signals for the rate multipliers. Amplifier IC201 level-shifts the input signal in such a way that the output at IC201-6 is an average DC level of the input waveform. Because of the relationship of R202 and R206, and the inversion caused by IC201, the DC signals cancel, at IC202-2 and zero-crossing information is provided at this point. Thus a DC offset is effectively created, without the input signal having to cross zero. The output of IC202 at pin 6 will now shift from +12 to -12V each time the zero crossing is simulated at the input.

This output is buffered out to the rate multipliers as well as to the output selection logic by serial buffers IC203-3 and IC203-11. These buffers process the output of IC202 to generate a clean trigger signal for the rate multipliers.

4.2.5 Rate Multipliers Description

The rate multipliers consist of IC1 through IC6, and thumbwheel switches S1 through S6. Each multiplier circuit includes a counter and a switch. Each stage is sensed by the following multiplier stage until the last stage represents a totalization of all the processing of the preceding stages.

If the thumbwheel switch S1 is selected to 1, the parallel outputs of S1 at S1-1, S1-3, S1-5 and S1-7 programs 0001 in BCD. This control signal causes the output at IC1-6 to produce one pulse for each ten pulses received at IC1-9. Similarly if S1 is selected to 2 the parallel outputs of S1 will program 0010. This condition forces IC1-6 to produce two pulses for each 10 pulses in at IC1-9. IC1 generates an Enable signal at IC1-7, which is connected into IC2-11 and -10, the Strobe and Enable in terminals of the counter second stage. The Enable Out pulse goes low once for every ten IC1 input clocks. Thus the clock of the second stage IC2 is now enabled only once for every ten times IC1 was clocked, effectively dividing-down the IC2 clock by a factor of 10.

If switch S2 is set to 0001, only one output will be generated by IC2 during the next 10 clocks enabled by the IC1 output, effectively dividing-down the IC3 clock by a factor of 100. The output of IC1 at pin 6 is connected to the cascade input of IC2, pin 12. This signal is ORed together with the output of IC2 internally. Therefore, the output of IC2 pin 6 is actually the sum of the IC1 and IC2 outputs. Now, if S1 is set to 1 and S2 is set to 2, the output at IC2 pin 6 will produce 12 pulses for every 100 clock pulses from the input circuit. IC3 through IC6 operate in the same manner as described for IC2. The final output at IC4 pin 6 is the sum of all the rate multiplier outputs and is connected to a differentiator which is described in paragraph 4.2.6.

If the unit is equipped with the FD (Frequency Doubling) option, the first scaling stage IC1 is removed and IC2 assumes the first position of the rate multipliers. Switch S1 is then used to gate the wave-shaped input signal into the differentiator circuit in a manner as described in the paragraph 4.2.6.

4.2.6 Logic Circuits Description

The logic circuits consist of OR gate IC203-10 and two differentiators. The output from the rate multipliers is differentiated by C202 and R207 to produce a 10 microsecond pulse at IC203-10. The trailing edge of this pulse triggers the one shot in the output circuit through coupling capacitor C204. The output of IC203 at pin 10 is also buffered by Q201 for the AP (Auxiliary Pulse Output) option.

If the unit is equipped with the FD option, IC1 is removed and switch S1 becomes a locking switch which can only be set to 0 or 1. When this switch is set to 1, the wave-shaped input signal is simply gated through to the differentiator made up of

C203 and R208. This produces another 10 microsecond pulse at IC203-10. Since this pulse occurs at the leading edge of the input signal and the pulse formed from the output of the rate multipliers occurs on the trailing edge of the input signal, both signals can be ORed together at IC203-10 without chance of coincidence. The effective result of this operation is an additional digit that may be used as a whole number multiplier to produce a scaling factor such as 1.9999.

4.2.7 Output Circuits Description

The output circuits consist of a one-shot multivibrator and two transistor drivers. The one-shot circuit consists of IC204 and associated components. The output of IC204 at pin 6 is normally low resulting in near ground potential of IC204-3. Pin 2 of IC204 is biased at one-half the supply voltage by resistors R202 and R213. When the output of IC203 of pin 10 goes low, it causes a negative voltage spike, which is limited by diode CR202, at IC204-2. This causes IC204-6 to go high and IC204-3 also goes high. As capacitor C205 starts to charge through R216, the voltage of IC204-3 exponentially decreases until it reaches just slightly below one-half the supply voltage. At this time IC204-6 goes low and capacitor C205 rapidly discharges through diode CR203. C205 and R216 are selected to produce a 30 millisecond pulse at IC204-6 for each trailing edge of the waveform at IC203-10. This pulse is then elevated to a 24 volt level with increased current capability by the output drivers Q2 and Q3.

4.3 ANALOG OUTPUT (AO OPTION)

4.3.1 Functional Description

The AO option consists of the functional elements illustrated in Figure 4-1. This figure also illustrates both an AC operated power supply and a DC operated power inverter. Please note that a unit will have either the power supply or the inverter but not both.

The incoming AC signal is transformer-coupled into a buffer that produces a trigger level compatible with the one-shot generator. The one-shot develops a signal whose repetition rate equals the frequency of the AC input signal. A switching stage inverts these pulses and provides a positive reference for the output stages. An active low-

pass filter consisting of two operational amplifiers produce a DC output proportional to the frequency of the applied AC input. Finally the unit output power is generated by a power amplifier stage. Except where otherwise indicated, refer to drawing 165-401-00 165-451-00, the main schematic diagram near the end of this manual, when reading these paragraphs.

4.3.2 Description of Power Inverter Circuit

The power inverter is a transformer-coupled multivibrator oscillating at approximately a 3 KHz rate. Because the core of the transformer is saturated, a square wave of reasonably constant amplitude is generated.

The components of the power inverter are mounted on a printed circuit board attached to the main board for standard units and are mounted directly on the main board for plug-in units. Drawing 400-404-00 is the schematic diagram of the power inverter (PCA) used on a standard unit. When a standard unit is ordered for use with DC power, the power inverter is used instead of the AC source T2 shown on the FDT schematic diagram. The DC applied to the power inverter is converted to a square wave of approximately 3 KHz by Q1, Q2 Q6, Q7, and the primaries of T1 (T2), functioning as a DC-to-AC inverter. Filter L1-C4 (C13) prevents the 3-KHz signal from getting back into the external DC source. CR1 (CR7) provides protection against damage from inadvertent application of DC of incorrect polarity. The square-wave output from center-tapped secondary 8-13 is applied to full-wave bridge, CR9 thru CR12 (CR4, CR5, CR10, CR11), and that from secondary 17-16 is applied to a full-wave bridge, CR4 thru CR7 (CR2, CR3, CR8, CR9).

4.3.3 Description of AC Power Supply Circuit

When AC power is applied, the power supply produces AC voltages of different amplitude (with respect to ground). These are applied to the rectifier and regulator, which develop regulated and unregulated DC as operating voltages for the unit.

The AC power supply circuit consists of a power transformer that produces two different AC outputs. Referring to the main schematic diagram, it is seen that VS1 is connected across the primary

of power transformer T2 and suppresses transients that may be present on the power line. Each half of the center-tapped secondary of T2 produces 18 volts, and the other secondary produces 36 volts. The voltage from the center-tapped secondary is applied to PC2, and that from the other secondary is applied to full wave rectifier CR4 thru CR7 (*CR2, CR3, CR8, CR9*).

4.3.4 Description of Rectifier and Regulator Circuit

The rectifier accepts the outputs from either the AC power supply or the power inverter and produces unregulated positive and negative voltages (of equal value with respect to ground). The regulator reduces these voltages to the required operating values and regulates them against changes with load or line-voltage changes.

Another rectifier produces a higher regulated output as operating voltage for the power amplifier. On all standard units, the components of the $\pm 12V$ regulator circuits are mounted on a printed circuit board attached to the main board (PC2). The +30V rectifiers and regulators for the +30V supply are mounted on the main board.

The blue and violet leads from either PCA or AC transformer T2 are connected to a full wave rectifier CR4 thru CR7 (*CR2, CR3, CR8, CR9*). Capacitor C2 (*C5*) filters the output, while VR1 and CR2 (*CR1*) provide the regulation for the +30V power to the unit.

The center-tapped outputs of AC transformer T2 or PCA pins ABC are connected to a full wave rectifier CR9 thru CR12 (*CR4, CR5, CR10, CR11*). The pulsating DC is filtered and regulated by C202 (*C7*), C204 (*C8*), VR202 (*VR2*) for +12V and C201 (*C9*), C203 (*C10*), and VR201 (*VR3*) for -12V supplier.

4.3.5 Description of Input Circuit and Wave Shaper Circuit

The input signal (which may be floating or not floating) is coupled by the transformer to the buffer comparator IC3 (*IC5*). For a direct coupled input, the transformer is not used and IC2 (*IC4*) with associated circuitry is added. This circuit level shifts the input signal so that the comparator, IC3 (*IC5*) will always see a zero crossing signal even if the input waveform is not. The output from the comparator produces a signal having a shape and amplitude suitable for driving the one-shot generator. This additional stage is necessary to improve the noise immunity and thus assure constant output pulses even in the presence of noise

on the input signal. Additional shaping also provides a signal with sharp transitions so the one-shot generator will be uniformly and reliably triggered regardless of the input waveform, thus insuring constant accuracy of the unit. The comparator operates from the +12V and -12V supplies.

Operational amplifier IC3 (*IC5*) is used as a comparator with controlled hysteresis. The signal from IC2 (*IC4*) is applied to the inverting input (pin 2) of IC3 (*IC5*) and feedback is applied through R14 (*R45*) to the non-inverting input (pin 3).

Controlling the hysteresis in this manner virtually eliminates the effect of noise when the signal crosses zero amplitude and thus provides reliable switching of this stage, thereby assuring equally reliable output even if some noise is present with a desired signal. The output from IC3 (*IC5*) is applied to CR1 (*CR13*), which eliminates the negative portion of the output, producing a 0 to +12V switching signal to the one-shot logic circuits.

4.3.6 One-Shot Generator Logic Circuits

The one-shot generator logic circuits consist of a clock generator, a binary counter, and two flip-flops. The clock circuit consists of a crystal oscillator X701, IC701, capacitor C701 and associated resistors. This circuit produces a 100 KHz free-running clock to the flip-flops and to the binary counter. The leading edge of the one-shot circuits output is shaped by two flip-flops IC702-13 and IC702-9. Signal from the comparator at IC702-14 occurs at the input frequency rate. As IC702-14 goes high, IC702-13 goes low at the next trailing edge of the clock. This condition triggers IC702-9. The flip-flop sets and a low level signal occurs on the base of switch transistor Q504, the input to the next stage.

Concurrently with flip-flop IC702-14 clocking, the same pulse from the clock generator triggers a binary ripple counter IC703. This counter is programmable by connecting any one of jumpers J701 thru J711 to count the desired numbers of clock times. Since each clock is 10 microseconds, IC703 counts-up in 10 microsecond increments. Just as the flip-flops IC702-9 goes high, the ripple counter IC703 begins to count clock pulses. IC701-9 goes low and IC701-8 high. When counter reaches full count as preset by jumpers. IC701-9 goes high. This condition forces IC701-8 low, resetting flip-flop IC702-9. The high stage of IC702-8 resets the counter, while inverter IC701-10 is forced high, triggering the switch transistor in the next stage.

4.3.7 Description of Switch Circuit

The switch, which includes a limiter, provides accurate near-ground and positive amplitude references for the pulses that are ultimately integrated to produce the DC output. The negative-going pulses from the one-shot generator are applied to the switch, which produces positive-going pulses of constant positive voltage above ground to drive the next stage in the required manner. A variable voltage divider applies a portion of the switch output to the following stage, thus effectively establishing the span of the unit. The switch (including the limiter) operates from the +12V supply.

The switch circuit consists of Q504 and associated components. Q504 is a switching transistor with a very low collector-to-emitter voltage under saturation. With the applied input signal to Q504 high, the transistor is saturated and the voltage at its emitter is practically zero (ground potential). When the input signal to Q504 becomes low, the transistor turns off rapidly, and the voltage at the emitter rises to +6.5 volts, as determined by transistor zener Q501. The voltage at the collector of Q501 remains at this value as long as the input signal remains low and returns to ground potential again when the input signal again becomes high, biasing the transistor on. Thus, the stage puts out a pulse train, tightly stabilized (clamped) in amplitude between essentially zero and +6.5 volts. A portion of the output signal, determined by R517 and the adjustment of the SPAN potentiometer, is applied to the next stage.

4.3.8 Description of Active Low-Pass Filter Circuit

The active low-pass filter consists of two operational amplifier stages with feedback and inverter to produce the required characteristics. These stages produce a DC output proportional to the frequency of the applied input signal. The second operational amplifier stage has associated with it a zero adjust circuit. This circuit adds an adjustable voltage of the proper polarity to the basic input signal for this stage. With zero signal applied to the unit, the zero adjust circuit is adjusted so the voltage added to the input of the second operational amplifier results in the required minimum output signal. The resulting signal from the output of the second operational amplifier is

then applied to the power amplifier. Both stages in the active low-pass filter and the zero adjust circuit operate from the +12V and -12V supplies.

The active low-pass filter circuit consists of two operational amplifier stages using integrated circuits IC507-1, IC504-7, and IC501, with feedback in each stage arranged to produce a low-pass output characteristic. The signal at the wiper of the SPAN potentiometer is applied through R516 and R530 to the inverting input of IC504-1. The adjustment of this potentiometer determines the maximum DC output, or span, of the unit with the maximum frequency applied at the input. R516, R530, and C504 form a low-pass filter for the signal applied to IC501-2 from the previous stage. C508 and R531 provide a feedback signal that changes in phase with increasing frequency in such a way that the stage exhibits a low-pass characteristic more pronounced than that provided by the filter at the input of the stage. The output from IC504-1 is applied through R529 to the next stage.

IC504-7 is arranged in a manner similar to that of IC504-1. A zero adjust circuit is also included in the IC504-7 stage. The zero adjust circuit is connected across ± 6.5 volts, regulated by Q502, Q503 and derived through R523, R524 from the ± 12 -volt output of the power supply. The voltage at the wiper of the ZERO potentiometer is adjusted so the unit produces the required minimum DC output with zero signal applied to the input. The combined signals (the signal from IC504-1 and that provided by the ZERO potentiometer) are processed through a low-pass filter, consisting of C506, C507 and R532 to the input of IC504. Feedback changing in phase with increasing frequency is provided from the power amplifier by C509 or C510 and R533, again resulting in a low-pass characteristic. In addition to creating the desired overall low-pass response, the use of two stages in the filter also completely eliminates any interaction between the SPAN and ZERO controls, since these controls are in separate stages. The positive output from IC504-7 is applied through R536 to the voltage divider for all voltage outputs. These circuits are operated from the ± 12 -volt supplies.

Inverting amplifier IC501 is used whenever a grounded current output is required of the FDT. In this case resistors R521, R522 and IC501 are inserted between IC504-1 and IC504-6 to provide

the inversion circuit necessary to develop a negative output at IC504-7. Because the pulses applied to the low-pass filter are of constant duration and occur at the input-frequency rate, the duty-cycle of these pulses is directly proportional to frequency. Passing these pulses through a low-pass filter recovers the DC component of the pulses, which is also directly proportional to frequency because the pulses are of constant amplitude. Thus, filtering the pulses developed and processed in the manner described results in a signal that drives the power amplifier so its output DC level is proportional to the input frequency.

4.3.9 Functional Description of Power Amplifier Circuit

The power amplifier is a DC-coupled stage that uses two PNP transistor stages. Feedback from the output is applied to the second operational amplifier in the active low-pass filter. This feedback results in high overall stability and a nearly ideal

output impedance for the type of output used (i.e., either current or voltage).

The power amplifier, consisting of Q505 and Q506 for current out, is a DC amplifier and can be arranged to provide either current or voltage output. For current output, the power amplifier is connected as a two-stage DC amplifier, with the output taken from the common connection of the two collectors. Feedback to pin 6 of IC504 is taken from the emitter circuit of Q506. R536 and R538 form a voltage divider to limit to a safe value the maximum overload current the output will supply. In units with the SC output, the optional selectable current output resistor replaces R534. For voltage output the output is taken directly from IC504-1, with feedback taken from the junction of R534 and R535. Capacitor C512 eliminates any AC from the output when the current output configuration is used. The power amplifier operates from +30 volts (floating).

MAINTENANCE & TROUBLESHOOTING

5.1 INTRODUCTION AND GENERAL INFORMATION

This section contains information to aid in the maintenance of the unit. This includes disassembly instructions for all mechanical options, as well as general troubleshooting. Precautions and special techniques required to replace components are also described.

5.2 DISASSEMBLY

When unit troubleshooting is required, it is first necessary to disassemble the unit. The physical configuration of the unit determines the steps to be followed in disassembly. These are described in the following paragraphs.

NOTE

Always identify wires — usually by tagging — before disconnecting existing connections.

CAUTION

DISCONNECT INPUT SIGNAL AND REMOVE POWER INPUT BEFORE DISASSEMBLING UNIT.

5.2.1 Disassembly of Standard Unit and Units With AB or CP Options

To disassemble a standard, AB, or CP unit, remove the unit from its installed position. If the mounting bracket is used, separate it from the unit by removing the two countersunk screws at the rear of the unit. After the unit has been removed from its installed position, disassemble the unit as follows to gain access to the circuit board.

- a. Remove the two front Phillips-head screws at the top of the unit.
- b. Remove the four Phillips-head screws at the bottom of the unit.
- c. Slide the front panel (with the circuit board still attached) down and free of the sides of the case. Points on the circuit board may now be reached for troubleshooting. It is

suggested that the case be used as a container for storing the removed hardware.

5.2.2 Disassembly of Unit in NEMA Boxes

Normally electrical connections are made to NEMA boxes through conduits. Units are secured on a mounting plate in the NEMA boxes. The following disassembly instructions apply to the various configurations.

Disassembly of Units in OT, WT and GP Enclosures. Use the following procedures to disassemble unit:

- a. Loosen clamps that hold hinged cover on OT and WT enclosures only, and open enclosure.
- b. Remove plastic safety cover from unit.
- c. Tag and disconnect wires from unit.
- d. Loosen four mounting screws that hold unit into box.
- e. Disassemble unit as described in paragraph 5.2.1.

Disassembly of Units in FG Enclosure. Use the following procedures to disassemble unit:

- a. Loosen four screws that secure cover on box.
- b. Open box and inspect gasket for damage. Replace if necessary.
- c. Remove plastic safety cover from unit.
- d. Tag and disconnect wires from unit.
- e. Tag and disconnect ground wire from conduit to mounting post.
- f. Remove four nuts that secure unit to mounting plate in rear of box.
- g. Disassemble unit as described in paragraph 5.2.1.

5.2.3 Disassembly of Units in PST or PB Enclosures

Use the following procedure to disassembly unit:

- a. Remove unit from terminal block by rocking it slightly while pulling upward.
- b. Remove two units, screws, washers, holding front panel to bottom of PC board (two front bottom).
- c. Remove two side screws from front panel.
- d. Remove one countersunk screw from back-bottom of unit in bottom of PC board.

Terminal block and card connector are keyed to eliminate error when the unit is reinstalled.

5.2.4 Disassembly of Units in EX Enclosures

Use the following procedure to disassemble unit:

- a. Using a bar wrench, attach to wrench lugs and loosen the housing cover from the base.
- b. Unscrew protective cover to expose unit.
- c. Use procedure of paragraph 5.2.3.

5.2.5 Disassembly of PM Units

Use the following procedure to disassemble unit. Refer to Figure 5-1 for parts nomenclature.

- a. Pull out safety cover to expose wiring.
- b. Tag and disconnect wires from terminal strip. If troubleshooting requires access to reverse side of PC board, perform the procedure described in next step.
- c. Remove screws holding cover to frame and lift cover off the case assembly.

CAUTION

WIRE SERVICE LOOP IS SUFFICIENT TO ALLOW PC BOARD AND END PLATE ASSEMBLIES TO BE TURNED OVER. ANY EXCESSIVE MOVEMENT OF THIS ASSEMBLY MAY CAUSE WIRING DAMAGE.

- d. Remove two nuts and washers that secure PC board and end plate into frame and carefully lift and slide board and plate towards terminal panel, out of end holder.

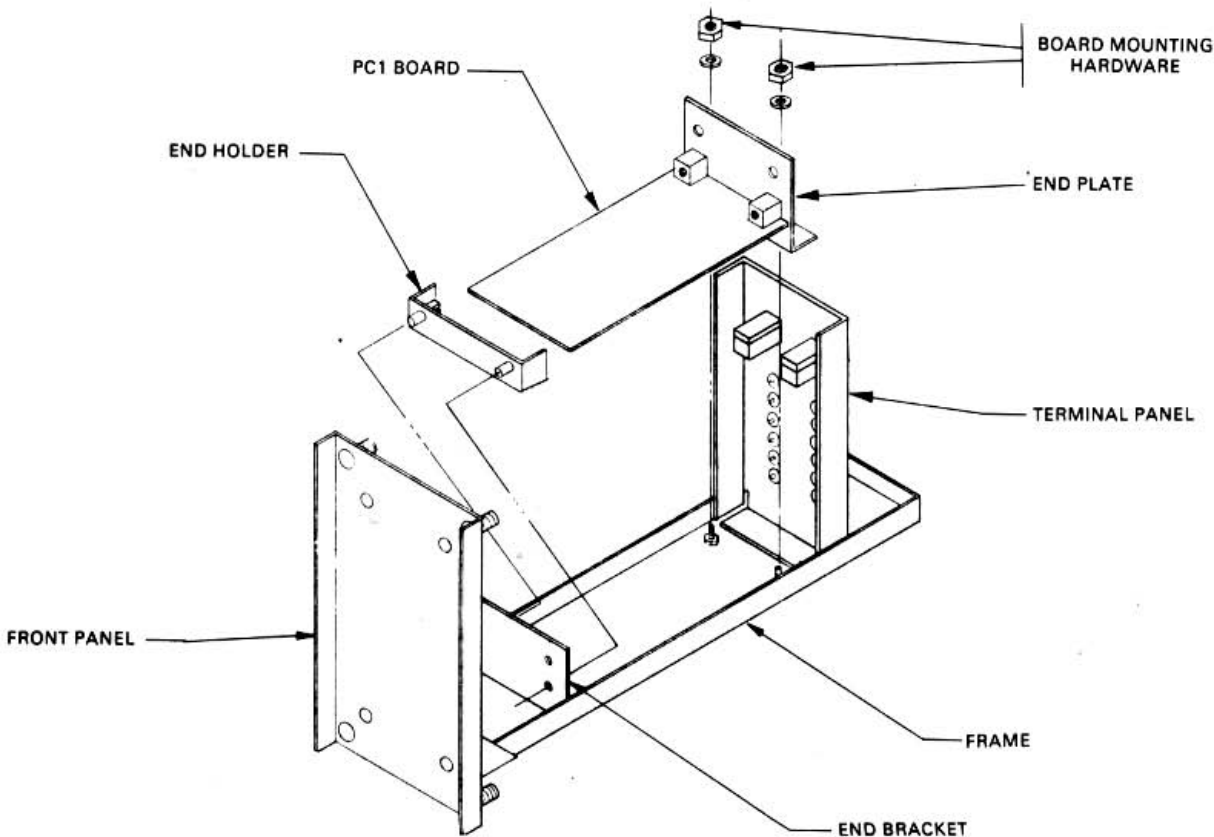

Figure 5-1. Disassembly of PM Units

5.3 TROUBLESHOOTING

The schematic diagrams include flagged numbers (or letters) at various points in the circuit. Table 5-1 gives the voltages and waveforms at these points for specified input-signal conditions. The assembly drawing shows the physical locations of the parts on the circuit board. Bear in mind that the circuit board is protected with a moisture-resistant coating. Therefore, it may be necessary to use a needle-point probe and exert a fair amount of pressure to break through the coating when it is desired to observe the signal or voltage at a specific point. When connecting a probe to a component on the circuit board, exercise care to make sure the probe does not short-circuit to an adjacent component.

In general, troubleshooting is carried out by tracing the signal with an oscilloscope and referring to the schematic diagrams to determine what component might be causing an observed abnormal indication. If the original symptom was a complete failure of the unit to operate, the most logical components to suspect are those associated with the power supply in the unit (including any voltage regulators). If the unit was producing an incorrect (but not zero) output, check the outputs from the voltage regulator and, if these are normal, apply a standard input signal and trace the resulting signal through the unit.

5.3.2 Component Replacement General Information

Replace all defective components with identical parts. Refer to Section 6 for a list of recommended replacement parts. The last row of numbers in the parts list is the number of spares recommended to be kept on hand for that part, per unit, for up to ten units of the same type. For more than ten units, a spares complement of 10% on the indicated parts should be used.

5.3.3 Component Replacement Techniques

Most parts used in the unit are quite small and are located in a confined area. Therefore, small hand tools are a necessity when servicing the unit. The following is a summary of the general techniques and precautions that should be observed to prevent damage to components in the unit:

CAUTION

CMOS INTEGRATED CIRCUITS ARE VERY SUSCEPTIBLE TO STATIC ELECTRICITY. WHEN REPLACING THESE COMPONENTS, DO NOT HANDLE LEADS BEFORE SOLDERING INTO BOARD. ENSURE THAT SOLDERING IRON IS GROUNDED. SOLDER INTEGRATED CIRCUITS LEAD V (POWER INPUT) BEFORE SOLDERING G (GROUND CONNECTION). FAILURE TO TAKE THESE PRECAUTIONS WILL DAMAGE COMPONENTS.

- a. Use a transformer-operated low-voltage soldering iron with a grounded tip and rated at not more than 50 watts. A temperature-controlled tip is desirable.
- b. Use extreme care when unsoldering the leads to any component. Do not keep the soldering iron on a point for more than a few seconds at a time. Use a suction-type solder-removing tool (solder sucker) as an aid in unsoldering transistors and integrated circuits. The protective coating on the unit may be removed with trichlorethane or equivalent. Be sure adequate ventilation is provided when using this or any other chemical.

NOTE

Unused connections on integrated circuits are left unsoldered to aid in removal. Refer to the assembly drawing for more complete information.



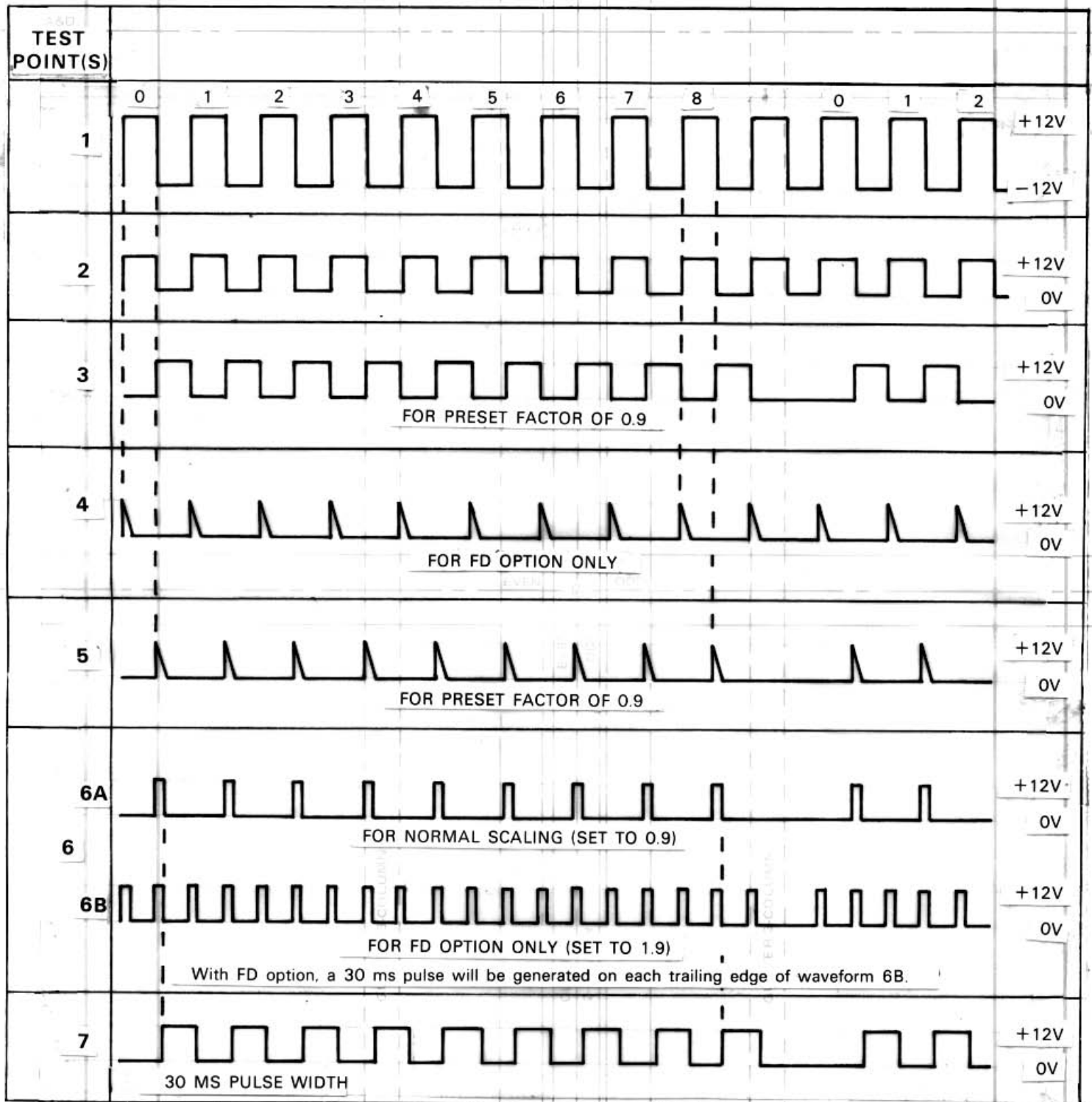

- c. Do not excessively bend or twist the leads of small components; they break easily.
- d. Before removing a component, observe the lead dress. Be sure that the lead dress of the replacement is the same as that of the original.
- e. Handle MOSFETs only by the case; if the fingers are allowed to contact the leads, the MOSFET may be ruined. Be sure to leave the metal sleeve around the leads until just before the device is installed on the printed circuit board.
- f. Remove all flux from soldered joints with trichlorethane or equivalent.

TABLE 5-1. WAVE FORMS AND VOLTAGES



- i. When reinstalling the unit onto the mounting bracket, be sure to use the same screws (or screws of the same size) as the ones removed. Longer screws will damage the unit.

TABLE 5-2 WAVEFORMS OR VOLTAGES FOR AO OPTION

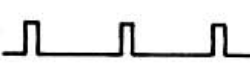
TEST POINT	WAVEFORM OR VOLTAGE LEVEL
8	 +12 -12V
9	 +12V 0
10	 +12V 0 (100 KHz)
11	 +12V 0
12	 6.5V 0
13	0 - - - - - 0 to -0.8V (See Note 2)
14	0.2 to 1V (See Note 2) Voltage Out 0 - - - - - (Current out is -0.2 to -1V)

NOTES:

1. Operating frequency is equal to the input frequency.
2. Low absolute value of amplitude corresponds to calibrated zero of input and high absolute value corresponds to calibrated full scale input.

Example: Waveform #6; input range is calibrated to 100 Hz. Therefore, A = 0V for zero input and -0.8V for 100 Hz input.

3. Test Point 8 replaces Test Point 1.

UNIT DOCUMENTATION

6.1 GENERAL

This section consists of a computer print-out table that provides parts identification information for the unit. Wiring lists have been provided in this section as an aid to the maintenance personnel.

Parts information is grouped according to the number of assemblies. If the unit contains two PC boards, the table will be divided into two major sections: one section will contain information related to PC1 and the other section will list PC2 components information. Each major section in the table contains a complete parts list headed LIST OF MATERIALS specifying which PC board it is describing. This list is usually found at the end of the section. The list of materials consists of the following headings:

ITEM: A reference numeral used for data processing and not used by maintenance personnel.

NAME: Gives the nomenclature of the part.

DESCRIPTION: Identifies the component by manufacturer's part number, usually followed by component's parameters or value.

REF: Lists the reference designation for the components described in Section 4 and illustrated in the schematics and assembly drawings.

PART NUMBER: This column specifies the Moore Industries assigned part number. This is the part identification required when ordering parts from Moore Industries.

SPARE: The numeral in this column specifies the recommended number of component spares per unit type that should be kept on hand by maintenance personnel.

6.2 GLOSSARY OF ABBREVIATIONS

C	Capacitor
CR	Diode — Zener included
HW	Special hardware
J	Connecting buss wire
L	Inductor
LBL	Label
PC	Printed circuit board
R	Resistor

T	Transformer
IC	Integrated circuit
Q	Transistor
LED	Light emitting diode
TB	Terminal block
VS	Voltage regulating varistor
VR	Voltage regulator
X	Crystal

TOLERANCES UNLESS NOTED	DRWNS G. TESSERS	7/18/77
X	±.1	
XX	±.03	
XXX	±.010	
ANGLES	±30'	

CHECKED	DATE
APPROVED	DATE
SCALE	

CATEGORY
SCHEMATIC

REVISED BY
ECC 3571

DATE	BY	APPROVAL
7/18/77		

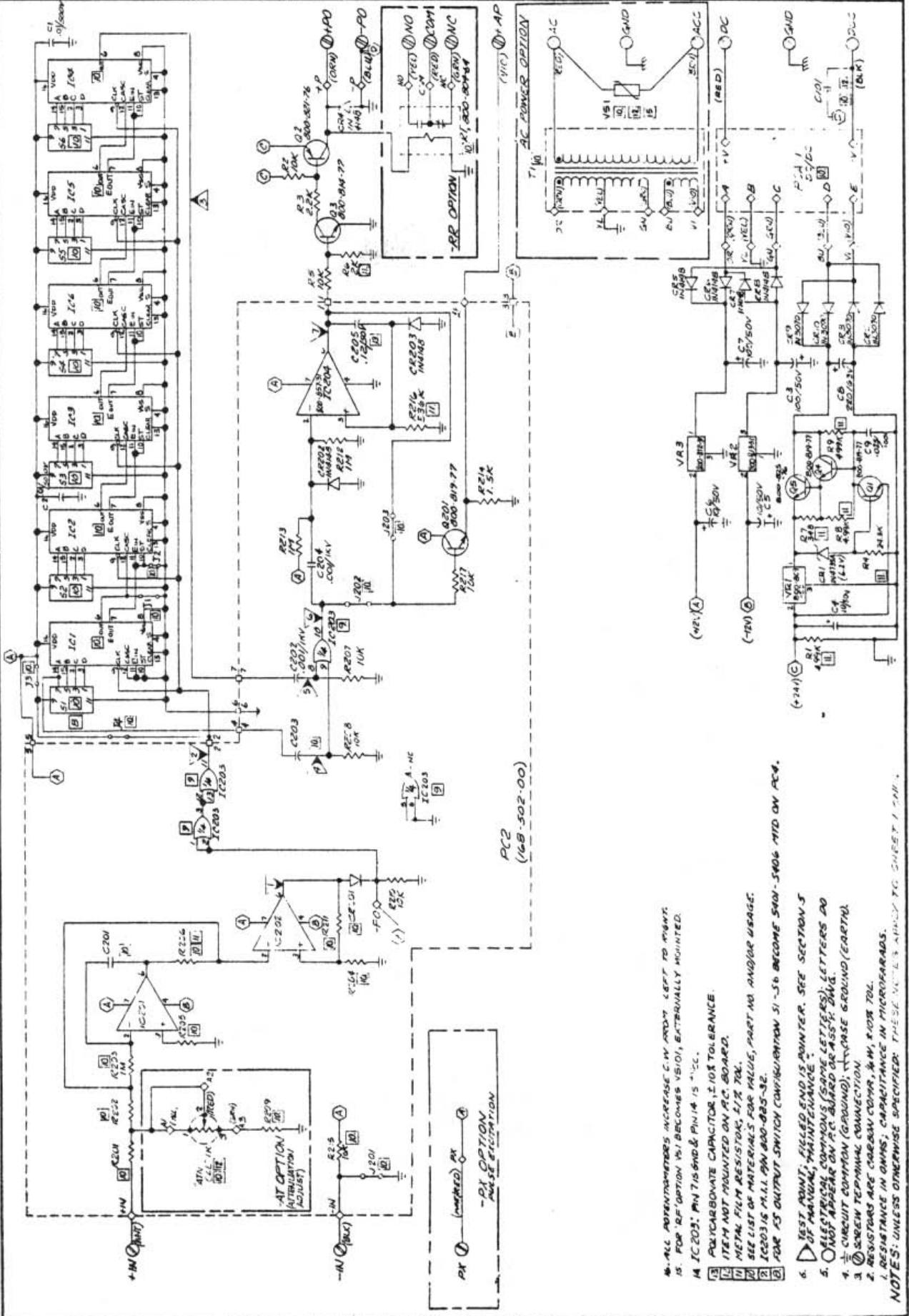

4. ALL ADJUSTMENT RESISTORS INCREASE C.W. ARMED. LEFT TO RIGHT.
 5. FOR RR OPTION V1 BECOMES VS10, EXTERNALLY MOUNTED.
 6. IC203: PIN 7 IS GND & PIN 14 IS V_{CC} .
 7. POLYCARBONATE CAPACITOR, ±10% TOLERANCE.
 8. ITEM NOT MOUNTED ON PC BOARD.
 9. METAL FILM RESISTOR, 1/2 TOL.
 10. SEE LIST OF MATERIALS FOR VALUES, PART NO. AND/OR USAGE.
 11. IC203 IS ALL PIN 800-883-32.
 12. FOR AS OUTPUT SWITCH CONFIGURATION S1-S6 BECOME S401-S406 MTD ON PC4.
 13. TEST POINT, FILLED END IS PUNTER. SEE SECTION 5.
 14. D: MOUNTED ON BOARD.
 15. O: ELEMENTS COMMON TO SOME LETTERS; LETTERS DO NOT APPEAR ON PC BOARD OR ASSY; DRAWING
 16. ⊕: CIRCUIT COMMON (GROUND); ⊖: CASE GROUND (EARTH).
 17. ⊙: SCREEN TERMINAL CONNECTION.
 18. RESISTORS ARE COORDINATED: M.M. ±10% TOL.
 19. RESISTANCE IN OHMS; CAPACITANCE IN MICROFARADS.
 NOTES: UNLESS OTHERWISE SPECIFIED: THESE VALUES APPLY TO SHEET 1 - 2-11.

DO NOT SCALE DRAWING	
TOLERANCES UNLESS NOTED	DATE 6/13/77
X ±.1	CHECKED
XX ±.03	ENGINEER J. J. [Signature]
XXX ±.010	SCALE NONE
ANGLES ±30'	

STANDARD
FSM
AO OPTION

DRAWING NUMBER 168-401-00	SHEET 2 OF 2
CATEGORY SCHEMATIC DIAGRAM	
REVISED BY SEE SH. 1	DATE
BY	APPROVAL

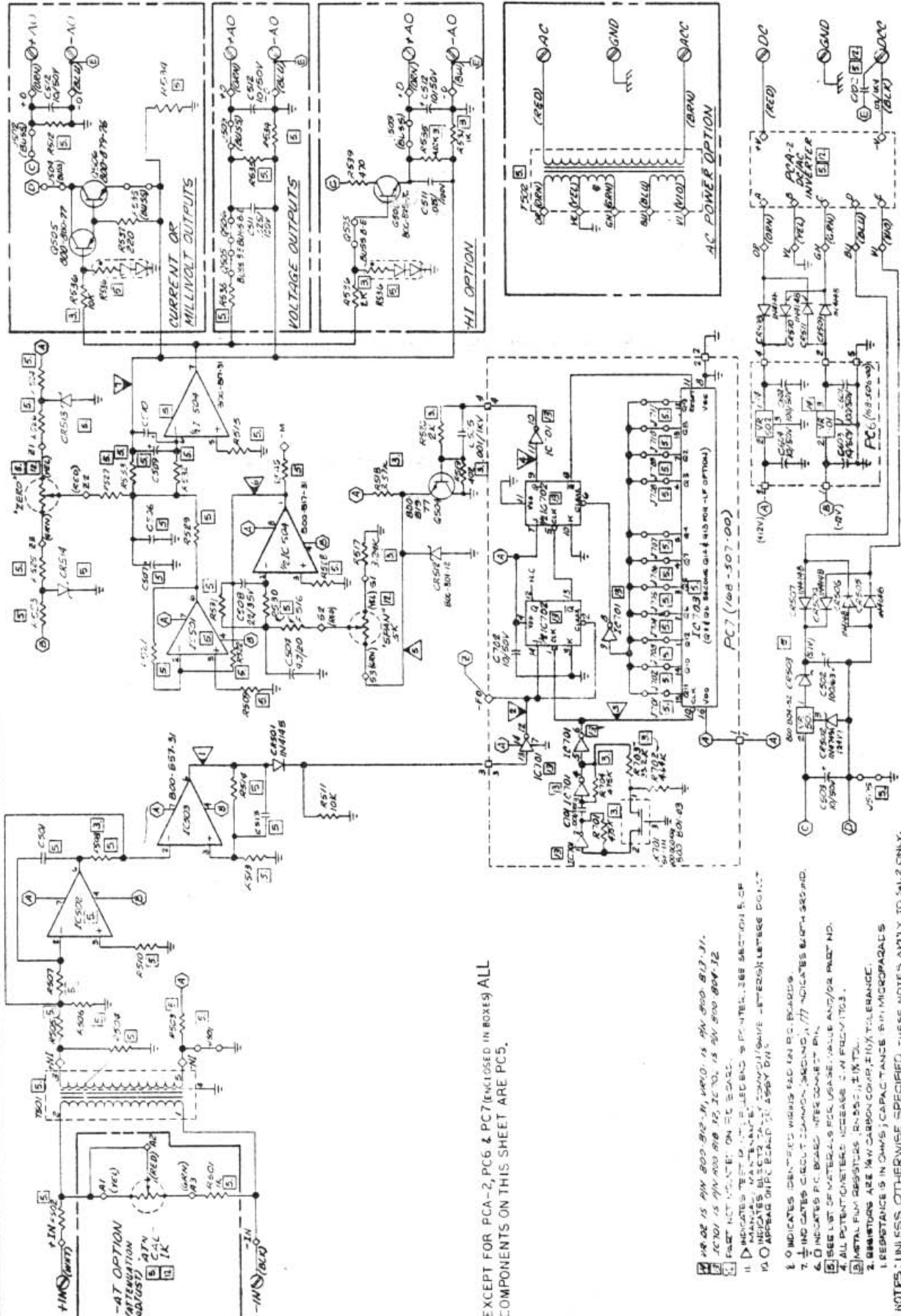

- NOTES: UNLESS OTHERWISE SPECIFIED, THESE NOTES APPLY TO SA1.2 ONLY.**
1. 0 INDICATES IDENTICAL PARTS WITHIN THIS BOARD.
 2. 1 INDICATES IDENTICAL PARTS WITHIN THIS BOARD.
 3. 2 INDICATES IDENTICAL PARTS WITHIN THIS BOARD.
 4. 3 INDICATES IDENTICAL PARTS WITHIN THIS BOARD.
 5. 4 INDICATES IDENTICAL PARTS WITHIN THIS BOARD.
 6. 5 INDICATES IDENTICAL PARTS WITHIN THIS BOARD.
 7. 6 INDICATES IDENTICAL PARTS WITHIN THIS BOARD.
 8. 7 INDICATES IDENTICAL PARTS WITHIN THIS BOARD.
 9. 8 INDICATES IDENTICAL PARTS WITHIN THIS BOARD.
 10. 9 INDICATES IDENTICAL PARTS WITHIN THIS BOARD.
 11. 10 INDICATES IDENTICAL PARTS WITHIN THIS BOARD.
 12. 11 INDICATES IDENTICAL PARTS WITHIN THIS BOARD.
 13. 12 INDICATES IDENTICAL PARTS WITHIN THIS BOARD.
 14. 13 INDICATES IDENTICAL PARTS WITHIN THIS BOARD.
 15. 14 INDICATES IDENTICAL PARTS WITHIN THIS BOARD.
 16. 15 INDICATES IDENTICAL PARTS WITHIN THIS BOARD.
 17. 16 INDICATES IDENTICAL PARTS WITHIN THIS BOARD.
 18. 17 INDICATES IDENTICAL PARTS WITHIN THIS BOARD.
 19. 18 INDICATES IDENTICAL PARTS WITHIN THIS BOARD.
 20. 19 INDICATES IDENTICAL PARTS WITHIN THIS BOARD.
 21. 20 INDICATES IDENTICAL PARTS WITHIN THIS BOARD.
 22. 21 INDICATES IDENTICAL PARTS WITHIN THIS BOARD.
 23. 22 INDICATES IDENTICAL PARTS WITHIN THIS BOARD.
 24. 23 INDICATES IDENTICAL PARTS WITHIN THIS BOARD.
 25. 24 INDICATES IDENTICAL PARTS WITHIN THIS BOARD.
 26. 25 INDICATES IDENTICAL PARTS WITHIN THIS BOARD.
 27. 26 INDICATES IDENTICAL PARTS WITHIN THIS BOARD.
 28. 27 INDICATES IDENTICAL PARTS WITHIN THIS BOARD.
 29. 28 INDICATES IDENTICAL PARTS WITHIN THIS BOARD.
 30. 29 INDICATES IDENTICAL PARTS WITHIN THIS BOARD.
 31. 30 INDICATES IDENTICAL PARTS WITHIN THIS BOARD.
 32. 31 INDICATES IDENTICAL PARTS WITHIN THIS BOARD.
 33. 32 INDICATES IDENTICAL PARTS WITHIN THIS BOARD.
 34. 33 INDICATES IDENTICAL PARTS WITHIN THIS BOARD.
 35. 34 INDICATES IDENTICAL PARTS WITHIN THIS BOARD.
 36. 35 INDICATES IDENTICAL PARTS WITHIN THIS BOARD.
 37. 36 INDICATES IDENTICAL PARTS WITHIN THIS BOARD.
 38. 37 INDICATES IDENTICAL PARTS WITHIN THIS BOARD.
 39. 38 INDICATES IDENTICAL PARTS WITHIN THIS BOARD.
 40. 39 INDICATES IDENTICAL PARTS WITHIN THIS BOARD.
 41. 40 INDICATES IDENTICAL PARTS WITHIN THIS BOARD.
 42. 41 INDICATES IDENTICAL PARTS WITHIN THIS BOARD.
 43. 42 INDICATES IDENTICAL PARTS WITHIN THIS BOARD.
 44. 43 INDICATES IDENTICAL PARTS WITHIN THIS BOARD.
 45. 44 INDICATES IDENTICAL PARTS WITHIN THIS BOARD.
 46. 45 INDICATES IDENTICAL PARTS WITHIN THIS BOARD.
 47. 46 INDICATES IDENTICAL PARTS WITHIN THIS BOARD.
 48. 47 INDICATES IDENTICAL PARTS WITHIN THIS BOARD.
 49. 48 INDICATES IDENTICAL PARTS WITHIN THIS BOARD.
 50. 49 INDICATES IDENTICAL PARTS WITHIN THIS BOARD.
 51. 50 INDICATES IDENTICAL PARTS WITHIN THIS BOARD.
 52. 51 INDICATES IDENTICAL PARTS WITHIN THIS BOARD.
 53. 52 INDICATES IDENTICAL PARTS WITHIN THIS BOARD.
 54. 53 INDICATES IDENTICAL PARTS WITHIN THIS BOARD.
 55. 54 INDICATES IDENTICAL PARTS WITHIN THIS BOARD.
 56. 55 INDICATES IDENTICAL PARTS WITHIN THIS BOARD.
 57. 56 INDICATES IDENTICAL PARTS WITHIN THIS BOARD.
 58. 57 INDICATES IDENTICAL PARTS WITHIN THIS BOARD.
 59. 58 INDICATES IDENTICAL PARTS WITHIN THIS BOARD.
 60. 59 INDICATES IDENTICAL PARTS WITHIN THIS BOARD.
 61. 60 INDICATES IDENTICAL PARTS WITHIN THIS BOARD.
 62. 61 INDICATES IDENTICAL PARTS WITHIN THIS BOARD.
 63. 62 INDICATES IDENTICAL PARTS WITHIN THIS BOARD.
 64. 63 INDICATES IDENTICAL PARTS WITHIN THIS BOARD.
 65. 64 INDICATES IDENTICAL PARTS WITHIN THIS BOARD.
 66. 65 INDICATES IDENTICAL PARTS WITHIN THIS BOARD.
 67. 66 INDICATES IDENTICAL PARTS WITHIN THIS BOARD.
 68. 67 INDICATES IDENTICAL PARTS WITHIN THIS BOARD.
 69. 68 INDICATES IDENTICAL PARTS WITHIN THIS BOARD.
 70. 69 INDICATES IDENTICAL PARTS WITHIN THIS BOARD.
 71. 70 INDICATES IDENTICAL PARTS WITHIN THIS BOARD.
 72. 71 INDICATES IDENTICAL PARTS WITHIN THIS BOARD.
 73. 72 INDICATES IDENTICAL PARTS WITHIN THIS BOARD.
 74. 73 INDICATES IDENTICAL PARTS WITHIN THIS BOARD.
 75. 74 INDICATES IDENTICAL PARTS WITHIN THIS BOARD.
 76. 75 INDICATES IDENTICAL PARTS WITHIN THIS BOARD.
 77. 76 INDICATES IDENTICAL PARTS WITHIN THIS BOARD.
 78. 77 INDICATES IDENTICAL PARTS WITHIN THIS BOARD.
 79. 78 INDICATES IDENTICAL PARTS WITHIN THIS BOARD.
 80. 79 INDICATES IDENTICAL PARTS WITHIN THIS BOARD.
 81. 80 INDICATES IDENTICAL PARTS WITHIN THIS BOARD.
 82. 81 INDICATES IDENTICAL PARTS WITHIN THIS BOARD.
 83. 82 INDICATES IDENTICAL PARTS WITHIN THIS BOARD.
 84. 83 INDICATES IDENTICAL PARTS WITHIN THIS BOARD.
 85. 84 INDICATES IDENTICAL PARTS WITHIN THIS BOARD.
 86. 85 INDICATES IDENTICAL PARTS WITHIN THIS BOARD.
 87. 86 INDICATES IDENTICAL PARTS WITHIN THIS BOARD.
 88. 87 INDICATES IDENTICAL PARTS WITHIN THIS BOARD.
 89. 88 INDICATES IDENTICAL PARTS WITHIN THIS BOARD.
 90. 89 INDICATES IDENTICAL PARTS WITHIN THIS BOARD.
 91. 90 INDICATES IDENTICAL PARTS WITHIN THIS BOARD.
 92. 91 INDICATES IDENTICAL PARTS WITHIN THIS BOARD.
 93. 92 INDICATES IDENTICAL PARTS WITHIN THIS BOARD.
 94. 93 INDICATES IDENTICAL PARTS WITHIN THIS BOARD.
 95. 94 INDICATES IDENTICAL PARTS WITHIN THIS BOARD.
 96. 95 INDICATES IDENTICAL PARTS WITHIN THIS BOARD.
 97. 96 INDICATES IDENTICAL PARTS WITHIN THIS BOARD.
 98. 97 INDICATES IDENTICAL PARTS WITHIN THIS BOARD.
 99. 98 INDICATES IDENTICAL PARTS WITHIN THIS BOARD.
 100. 99 INDICATES IDENTICAL PARTS WITHIN THIS BOARD.



MOORE INDUSTRIES
16650 Schoenborn Street
Sepulveda, California 91343

DO NOT SCALE DRAWING

TOLERANCES
UNLESS NOTED
X ±.1
XX ±.03
XXX ±.010
ANGLES ±.30°

DRAWN *D. Santini* 26 APR 82
CHECKED *L. S. Nunez* 11/4/82
ENGINEER *J. Lopez* 7/1/82
SCALE 2/1

FSM
STANDARD
PCI

DRAWING NUMBER 168-501-00	REVISION K
CATEGORY ASSEMBLY	
REVISED BY ECO 6.714	DATE 2/5/88
BY <i>[Signature]</i>	APPROVAL <i>[Signature]</i>

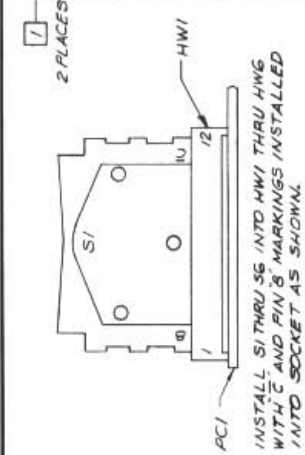
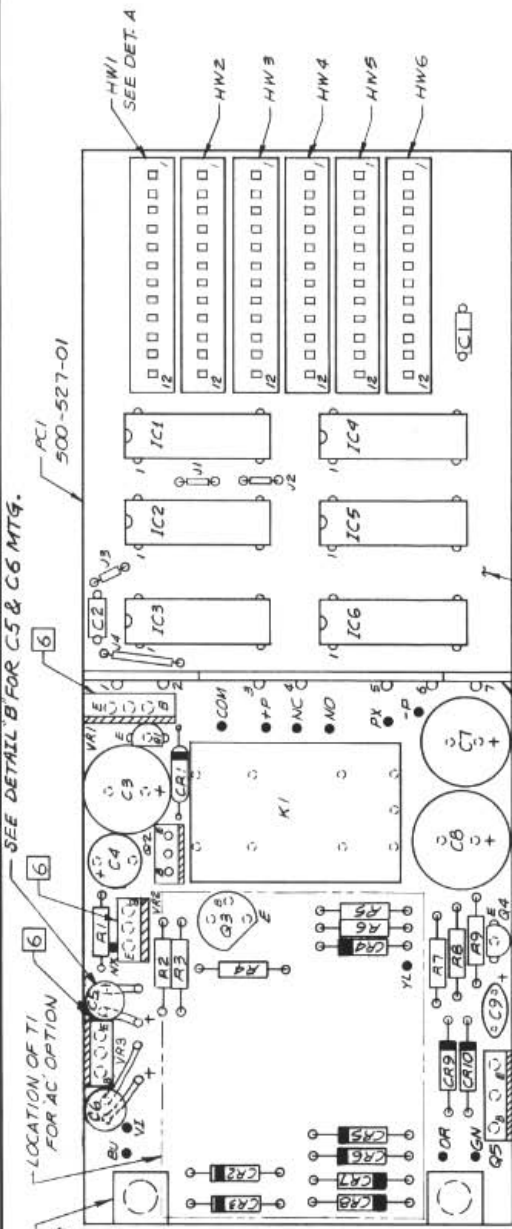

DETAIL A
(FOR IS OUTPUT SWITCH CONFIG)
(6 PLACES)

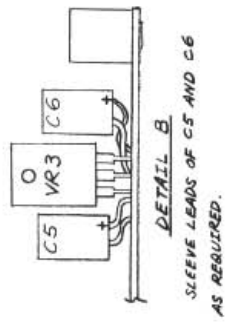

DETAIL B
SLEEVE LEADS OF C5 AND C6
AS REQUIRED.

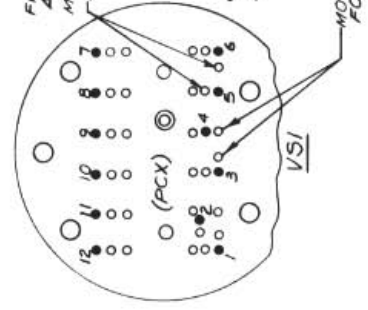
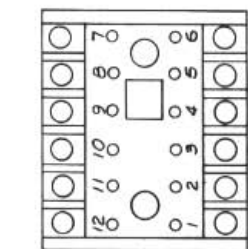
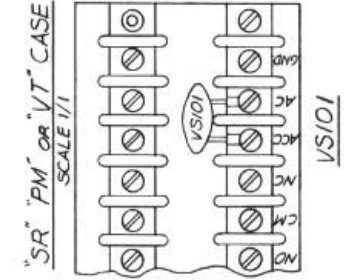
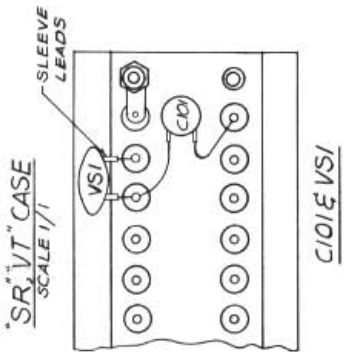

- 6 APPLY SLEEVING TO METAL TAB AT ASSEMBLY.
- 5 ALL WIRING TO BE 22AWG STRANDED; JUMPERS TO BE 22AWG TEFLON, SLEEVING AS REQUIRED.
- 4.
- 3 ALL LEADS MUST BE SOLDERED TO PADS (CIRCUIT SIDE ONLY).
- 2 METAL SIDE OF G2, G3, G5, VR1, VR2, VR3.
- 1 SWAGE MOUNTING BLOCKS TO PCI BEFORE ADDING COMPONENTS; SEE CASE ASSY FOR POSITIONING OF BLOCKS.

NOTES: UNLESS OTHERWISE SPECIFIED:

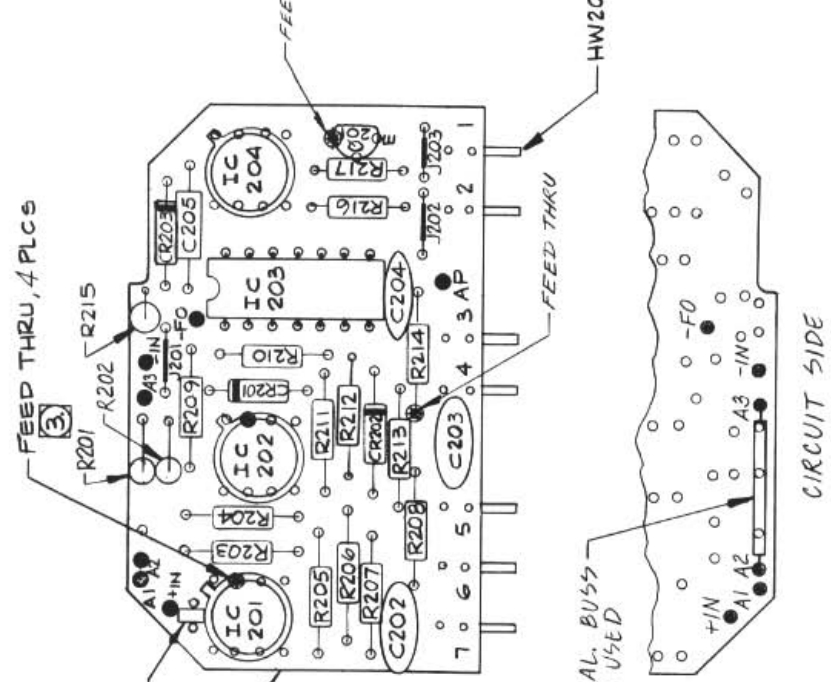
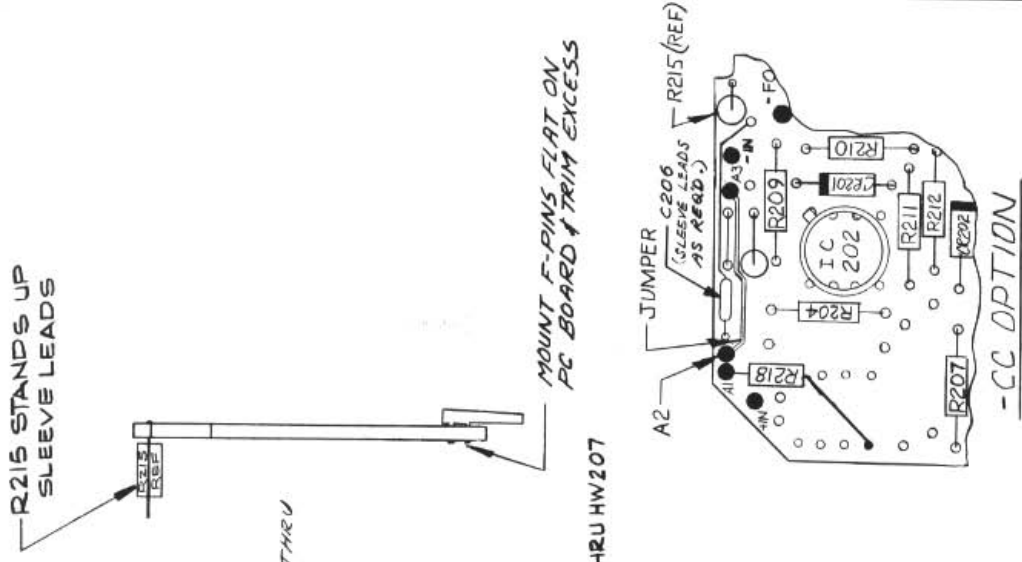

3. WHEN PART IS NOT USED USE A FEED THRU AS SHOWN.
2. ALL JUMPERS ARE 22AWG BUSS, TEFLON SLEEVED AS REQ'D.
1. ALL LEADS MUST BE SOLDERED TO PADS.
- NOTES: UNLESS OTHERWISE SPECIFIED**



MOORE INDUSTRIES
16650 Schoenborn Street
Sepulveda, California 91343

DO NOT SCALE DRAWING

TOLERANCES
UNLESS NOTED
.X ±.1
.XX ±.03
.XXX ±.010
ANGLES ±30'

DRAWN BY **TESSER** 4/77
ENGR. BY **[Signature]** 4/77
NUMBER
SCALE **2/1**

STANDARD
FSM
PC3-PC4
-FS" OPTION

DRAWING NUMBER
168-503-00

REVISION
D

CATEGORY
P.C. ASSEMBLY

REVISED BY
ECO @714

DATE
2/4/78
BY
CA
APPROVAL
[Signature]

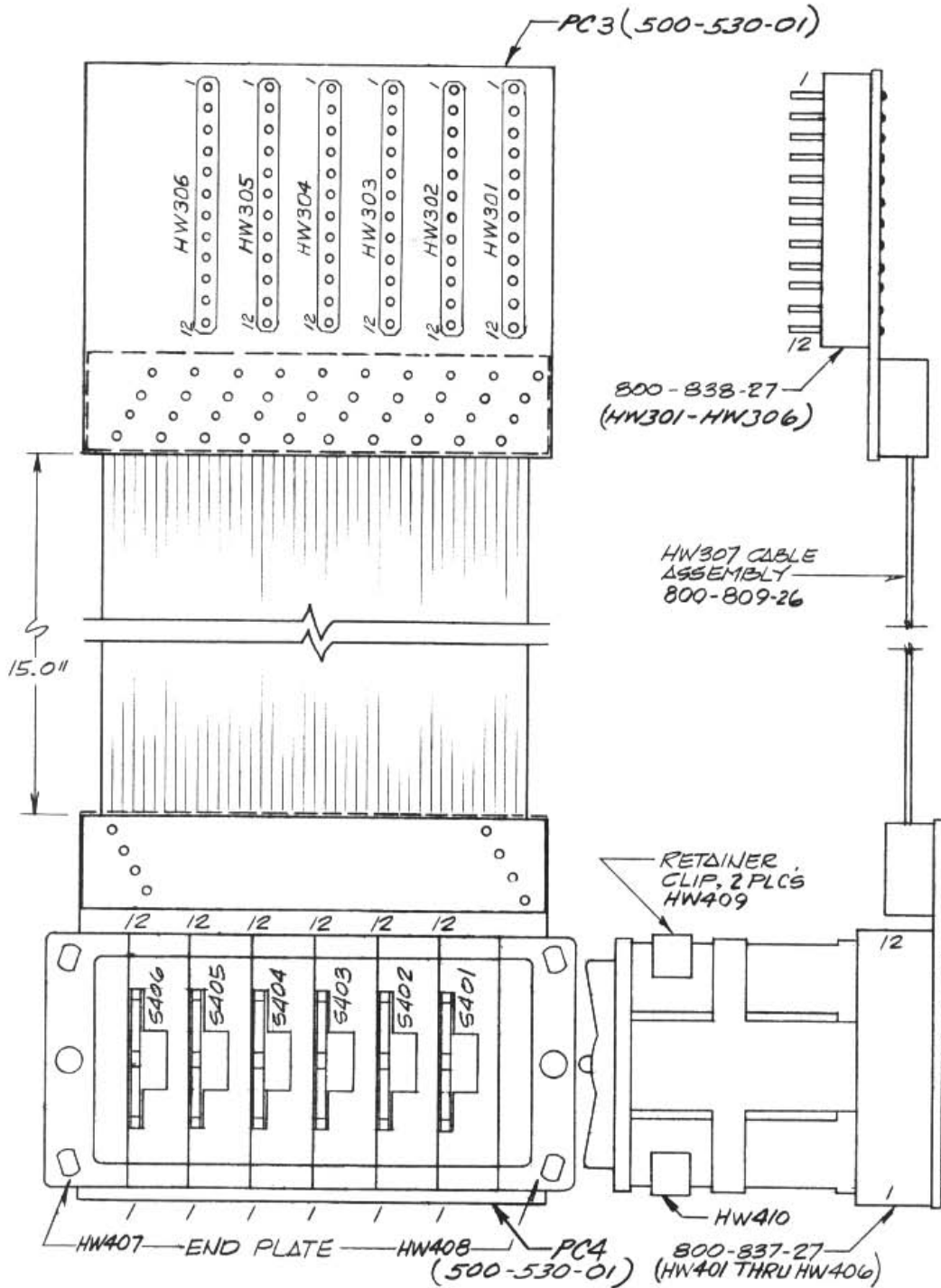

3. TRIM OFF EXCESS LEADS.
 2. THESE BOARDS HAVE PLATED-THRU HOLES.
 1. ALL LEADS MUST BE SOLDERED TO PADS.
- NOTES: UNLESS OTHERWISE SPECIFIED.**

MOORE INDUSTRIES
 16650 Schoenborn Street
 Sepulveda, California 91343

DO NOT SCALE DRAWING

TOLERANCES
 UNLESS NOTED
 X ±.1
 XX ±.03
 XXX ±.010
 ANGLES ±30°

DESIGNED BY G. TESSERS
 CHECKED BY [Signature]
 DRAWN BY [Signature]
 SCALE 2/1

STANDARD
 FSM
 PC5
 "AO" OPTION

DRAWING NUMBER
 168-505-00

CATEGORY
 PC ASSEMBLY

REVISED BY
 EC 06714

DATE 1/18/72
 BY [Signature]
 APPROVAL [Signature]

(SEE SHT. 2 FOR CONTINUATION OF NOTES)

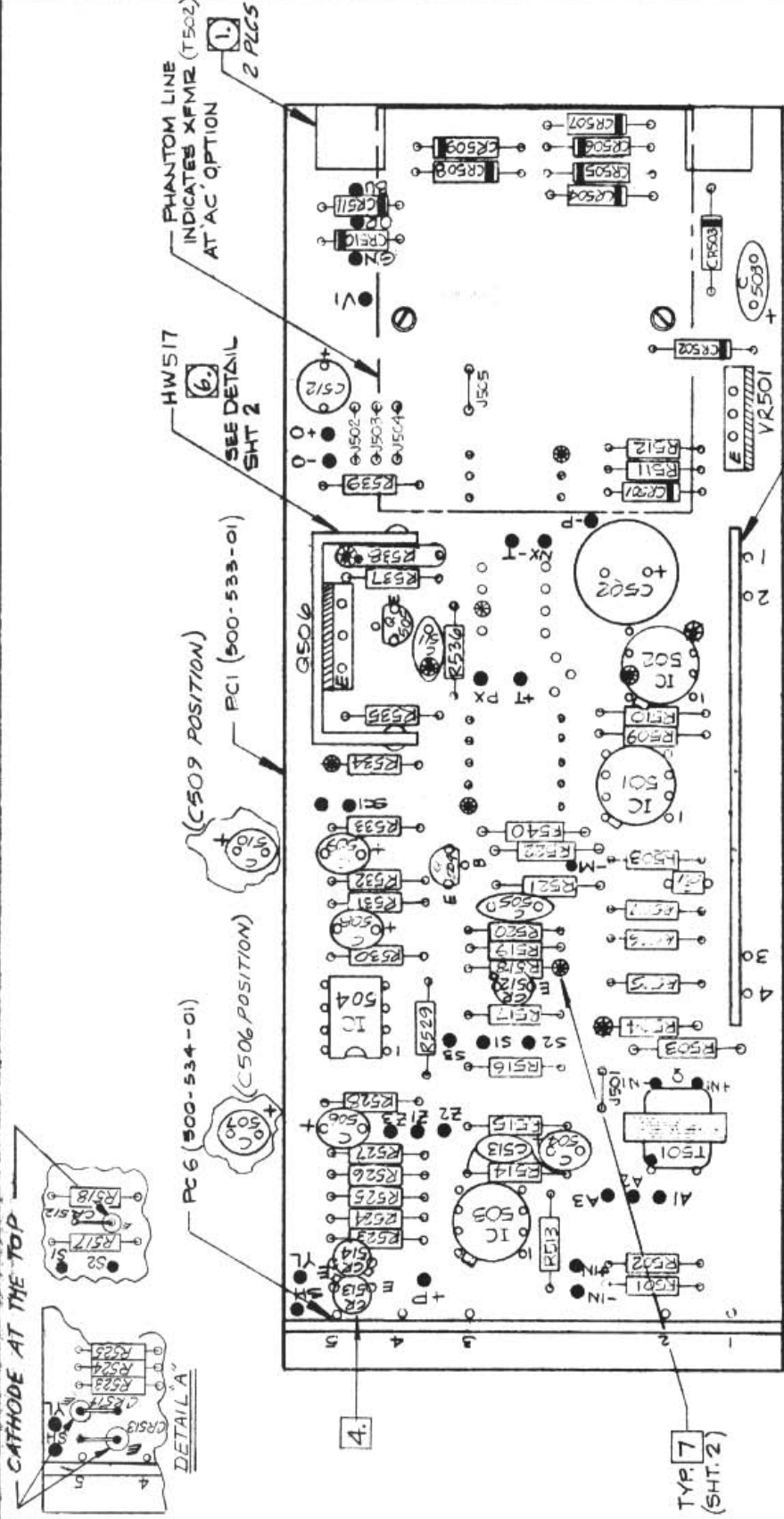

6. APPLY THERMACOTE JOINT COMPOUND (OR EQUIV.) BETWEEN HWS17 & METAL SIDE OF Q506
 5. ALL WIRING 22 AWG STRANDED, ALL JUMPER
 22 AWG, TEFLON SLEEVED AS REQUIRED.

4. POSITION BLACK DOT ON CR512, CR513, CR514 AT "E" HOLE ON BOARD
 SEE DETAIL "A" FOR ALT. CR512, 513 & 514 MOUNTING.

3. ALL LEADS MUST BE SOLDERED TO PADS.
 2. [Symbol] : METAL SIDE OF VR501 & Q506.

1. SWAGE MOUNTING BLOCKS TO PC1 BEFORE ADDING COMPONENTS;
 SEE TRAVELER FOR CASE ASS'Y # LOCATION OF MFG. BLOCKS.

NOTES: UNLESS OTHERWISE SPECIFIED (CONTINUED ON SHEET 2)

MOORE INDUSTRIES
 16650 Schoenborn Street
 Sepulveda, California 91343

DO NOT SCALE DRAWING	
TOLERANCES UNLESS NOTED	DRAWN BY G. TESSERA 6/21/77
X ± .1	CHECKED BY [Signature] 7/1/77
XX ± .03	DESIGNED BY [Signature]
XXX ± .010	SCALE NONE
ANGLES ± 30'	

STANDARD
 FSM
 PC5
 "A0" OPTION

DRAWING NUMBER	168-505-00	REVISED	E
CATEGORY	P.C. ASSEMBLY		
REVISED BY	DATE	BY	APPROVED

(TRIM OFF TAB AT REAR OF HEATSINK)

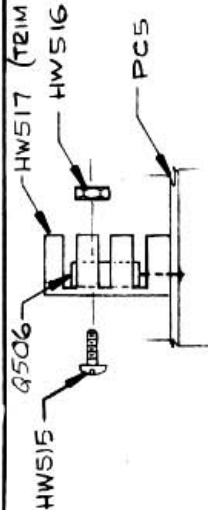

MTG. DETAIL FOR Q506
 (SIDE VIEW)

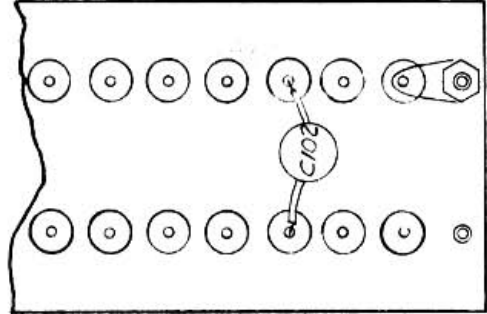

C102
 (SLEEVE LEADS REAR OF PANEL SHOWN)

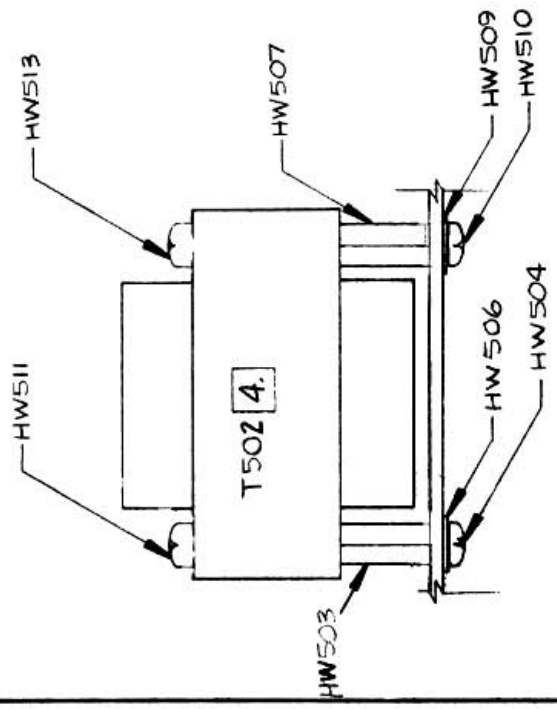

MTG. DETAIL FOR T502

7 ● INDICATES FEED THRU; BUSS WHEN COMPONENT IS NOT USED.
 NOTES: (CONTINUED)



MOORE INDUSTRIES
16650 Schoenborn Street
Sepulveda, California 91343

DO NOT SCALE DRAWING

TOLERANCES UNLESS NOTED

.X ±.1
.XX ±.03
.XXX ±.010
ANGLES ±.30°

DATE: 11/77
SCALE: 2/1

STANDARD
FSM
PCE
"AC OPTION"

168-506-00 A
ASSEMBLY
INITIAL RELEASE
APPROVED: RC

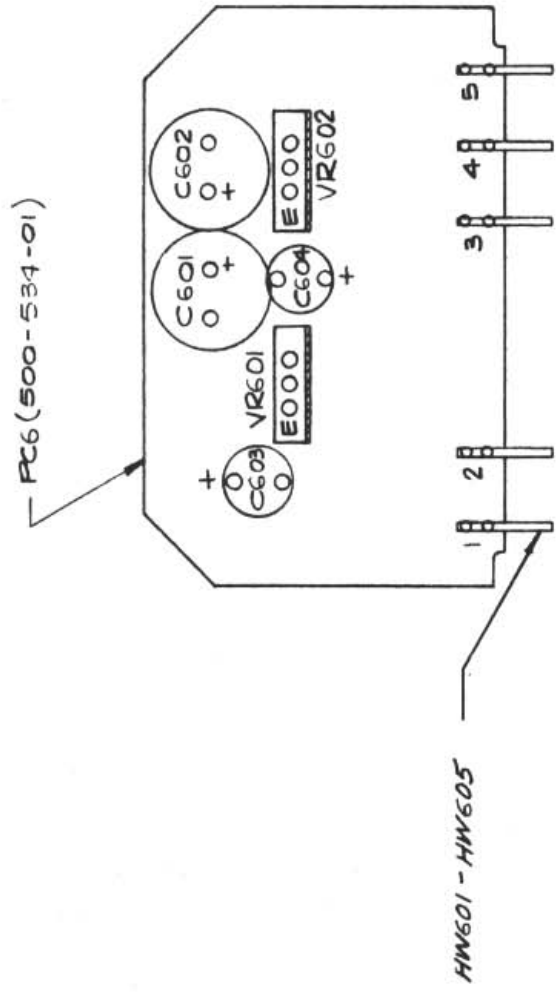
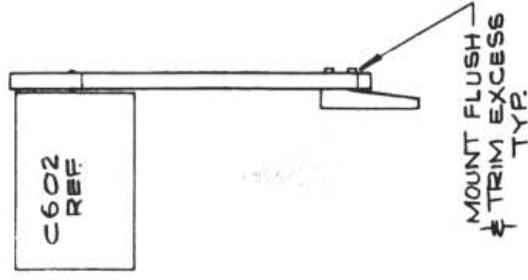

- 2. ALL LEADS MUST BE SOLDERED TO PADS.
- 1 METAL SIDE OF VR601 & VR602

NOTES: UNLESS OTHERWISE SPECIFIED



MOORE INDUSTRIES
 16650 Schoenborn Street
 Sepulveda, California 91343

DO NOT SCALE DRAWING	
TOLERANCES UNLESS NOTED	DRAWN J.A. Diller 6/9/77
X ±1	CHECKED J. Janssen 6/13/77
XX ±0.03	ENGINEER
XXX ±.010	SCALE 2/1
ANGLES ±30°	

STANDARD FORM
PC7
 "A" OPTION

DRAWING NUMBER 166-507-00	REVISION A
CATEGORY ASSEMBLY	REVISOR BY INITIAL RELEASE
DATE 6/77	BY ref
APPROVAL MC	

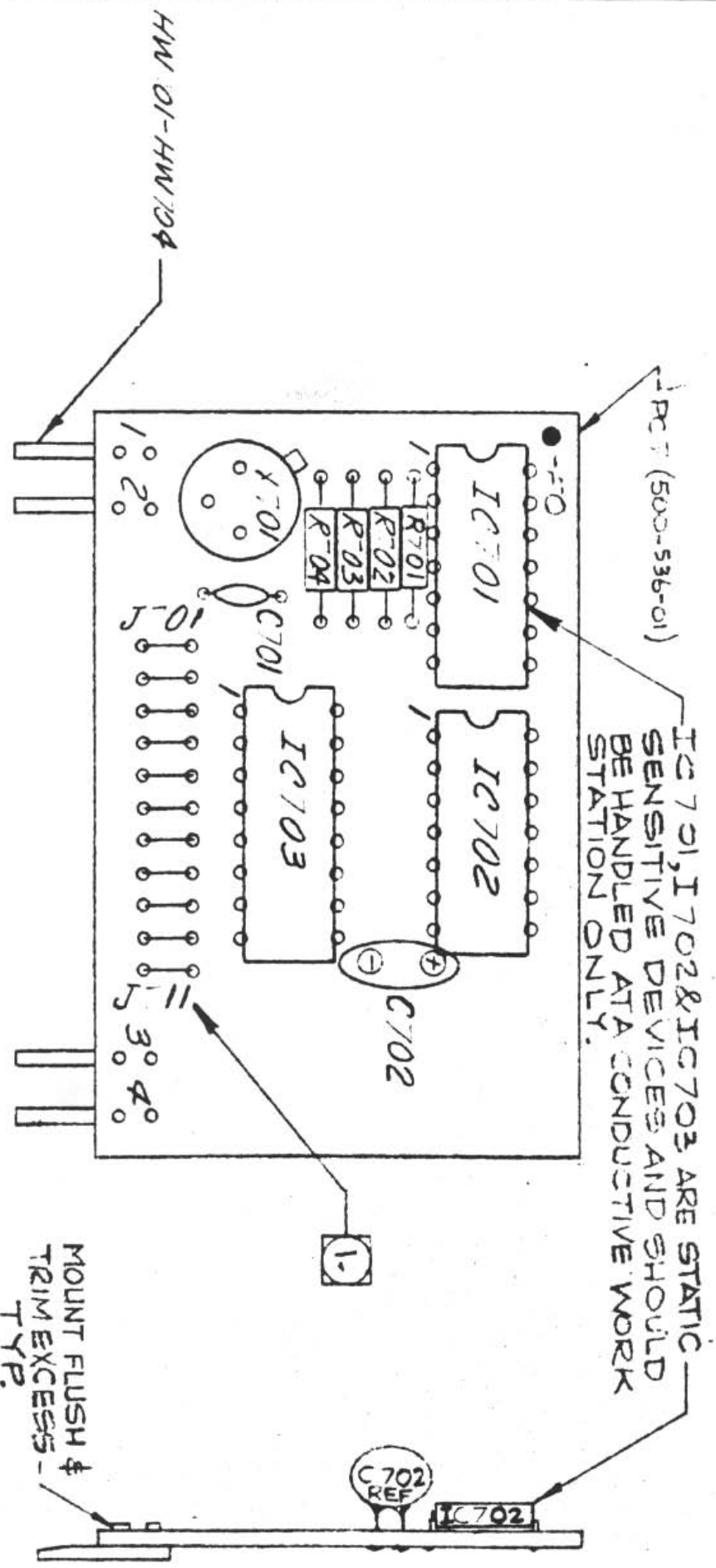

3. ALL LEADS MUST BE SOLDERED TO PADS.
 2. ALL JUMPERS ARE 22AWG TEFLON SLEEVED.
 - ① J701 THROUGH J711 ARE ALL SHOWN FOR REFERENCE; ONLY ONE WILL BE USED PER UNIT, SEE L/M FOR SELECTION.
- NOTE: UNLESS OTHERWISE SPECIFIED

RETURN PROCEDURES

To return equipment to Moore Industries for repair, follow these four steps:

1. Call Moore Industries and request a Returned Material Authorization (RMA) number.

Warranty Repair –

If you are unsure if your unit is still under warranty, we can use the unit's serial number to verify the warranty status for you over the phone. Be sure to include the RMA number on all documentation.

Non-Warranty Repair –

If your unit is out of warranty, be prepared to give us a Purchase Order number when you call. In most cases, we will be able to quote you the repair costs at that time. The repair price you are quoted will be a "Not To Exceed" price, which means that the actual repair costs may be less than the quote. Be sure to include the RMA number on all documentation.

2. Provide us with the following documentation:
 - a) A note listing the symptoms that indicate the unit needs repair
 - b) Complete shipping information for return of the equipment after repair
 - c) The name and phone number of the person to contact if questions arise at the factory
3. Use sufficient packing material and carefully pack the equipment in a sturdy shipping container.
4. Ship the equipment to the Moore Industries location nearest you.

The returned equipment will be inspected and tested at the factory. A Moore Industries representative will contact the person designated on your documentation if more information is needed. The repaired equipment, or its replacement, will be returned to you in accordance with the shipping instructions furnished in your documentation.

WARRANTY DISCLAIMER

THE COMPANY MAKES NO EXPRESS, IMPLIED OR STATUTORY WARRANTIES (INCLUDING ANY WARRANTY OF MERCHANTABILITY OR OF FITNESS FOR A PARTICULAR PURPOSE) WITH RESPECT TO ANY GOODS OR SERVICES SOLD BY THE COMPANY. THE COMPANY DISCLAIMS ALL WARRANTIES ARISING FROM ANY COURSE OF DEALING OR TRADE USAGE, AND ANY BUYER OF GOODS OR SERVICES FROM THE COMPANY ACKNOWLEDGES THAT THERE ARE NO WARRANTIES IMPLIED BY CUSTOM OR USAGE IN THE TRADE OF THE BUYER AND OF THE COMPANY, AND THAT ANY PRIOR DEALINGS OF THE BUYER WITH THE COMPANY DO NOT IMPLY THAT THE COMPANY WARRANTS THE GOODS OR SERVICES IN ANY WAY.

ANY BUYER OF GOODS OR SERVICES FROM THE COMPANY AGREES WITH THE COMPANY THAT THE SOLE AND EXCLUSIVE REMEDIES FOR BREACH OF ANY WARRANTY CONCERNING THE GOODS OR SERVICES SHALL BE FOR THE COMPANY, AT ITS OPTION, TO REPAIR OR REPLACE THE GOODS OR SERVICES OR REFUND THE PURCHASE PRICE. THE COMPANY SHALL IN NO EVENT BE LIABLE FOR ANY CONSEQUENTIAL OR INCIDENTAL DAMAGES EVEN IF THE COMPANY FAILS IN ANY ATTEMPT TO REMEDY DEFECTS IN THE GOODS OR SERVICES, BUT IN SUCH CASE THE BUYER SHALL BE ENTITLED TO NO MORE THAN A REFUND OF ALL MONIES PAID TO THE COMPANY BY THE BUYER FOR PURCHASE OF THE GOODS OR SERVICES.

ANY CAUSE OF ACTION FOR BREACH OF ANY WARRANTY BY THE COMPANY SHALL BE BARRED UNLESS THE COMPANY RECEIVES FROM THE BUYER A WRITTEN NOTICE OF THE ALLEGED DEFECT OR BREACH WITHIN TEN DAYS FROM THE EARLIEST DATE ON WHICH THE BUYER COULD REASONABLY HAVE DISCOVERED THE ALLEGED DEFECT OR BREACH, AND NO ACTION FOR THE BREACH OF ANY WARRANTY SHALL BE COMMENCED BY THE BUYER ANY LATER THAN TWELVE MONTHS FROM THE EARLIEST DATE ON WHICH THE BUYER COULD REASONABLY HAVE DISCOVERED THE ALLEGED DEFECT OR BREACH.

RETURN POLICY

For a period of thirty-six (36) months from the date of shipment, and under normal conditions of use and service, Moore Industries ("The Company") will at its option replace, repair or refund the purchase price for any of its manufactured products found, upon return to the Company (transportation charges prepaid and otherwise in accordance with the return procedures established by The Company), to be defective in material or workmanship. This policy extends to the original Buyer only and not to Buyer's customers or the users of Buyer's products, unless Buyer is an engineering contractor in which case the policy shall extend to Buyer's immediate customer only. This policy shall not apply if the product has been subject to alteration, misuse, accident, neglect or improper application, installation, or operation. THE COMPANY SHALL IN NO EVENT BE LIABLE FOR ANY INCIDENTAL OR CONSEQUENTIAL DAMAGES.



WORLDWIDE • www.miinet.com

United States • info@miinet.com Tel: (818) 894-7111 • FAX: (818) 891-2816	Belgium • info@mooreind.be Tel: 03/448.10.18 • FAX: 03/440.17.97	China • sales@mooreind.sh.cn Tel: 86-21-62491499 • FAX: 86-21-62490635
Australia • sales@mooreind.com.au Tel: (02) 8536-7200 • FAX: (02) 9525-7296	The Netherlands • sales@mooreind.nl Tel: (0)344-617971 • FAX: (0)344-615920	United Kingdom • sales@mooreind.com Tel: 01293 514488 • FAX: 01293 536852